

Instruction and Operation Manual



S332 Display and Data Logger



Dear Customer,

Thank you for choosing our product.

The operating instructions must be read in full and carefully observed before starting up the device. The manufacturer cannot be held liable for any damage which occurs as a result of non-observance or non-compliance with this manual.

Should the device be tampered with in any manner other than a procedure which is described and specified in the manual, the warranty is cancelled and the manufacturer is exempt from liability.

The device is destined exclusively for the described application.

SUTO iTEC offers no guarantee for the suitability for any other purpose. SUTO iTEC is also not liable for consequential damage resulting from the delivery, capability or use of this device.

Reversion: 2026-1



Last modifications: July, 2026

Table of Contents

1	Safety Instructions	5
2	Registered Trademarks	6
3	Introduction	7
4	Features	7
5	Technical Data	8
	5.1 General	8
	5.2 Electrical Data	8
	5.3 Input-Signals	8
	5.4 Output-Signals	8
	5.5 Data Interface	9
	5.6 Environment Data	9
6	Dimension and Installation	10
7	Installation	13
	7.1 Installation Requirements	13
	7.2 Safety Instructions	13
	7.2.1 Protective Grounding	13
	7.2.2 Overcurrent Protection — AC Version Only	14
8	Electrical Connections	15
	8.1 Power Supply Connection (X1)	16
	8.2 Relay Output Connection (X2, X3)	16
	8.3 Power Output Connection (X4)	17
	8.4 Ethernet Connection (X5)	17
	8.5 Modbus Slave (X7)	17
	8.6 Modbus Master (X8)	18
	8.6.1 Pin Assignment	18
	8.6.2 Connection between S332 and SUTO iTEC Sensor	18
	8.6.3 Modbus/RTU Cable Length	19
	8.6.4 Modbus/RTU Wiring and Cable Specifications	19
	8.6.5 Daisy-Chain Configuration using RS-485 Splitter	20
	8.7 Analog / Digital / Relays Module Connection (X9..X16)	21
	8.7.1 Analog Input Connection (Option Module)	21
	8.7.2 Digital Input Connection (Option Module)	23
	8.7.3 Relay Module Connection (Option Module)	24
9	Operation	26
	9.1 S4C Web Interface	26
	9.2 Login	28
	9.3 Sensor Configuration	29
	9.3.1 SUTO iTEC Sensor	29
	9.3.2 3rd-Party Sensor	32
	9.3.3 Analog & Digital Input	34
	9.3.4 Virtual Channel	36
	9.3.5 Live-View Layout	38
	9.4 Home	40
	9.5 Chart	41

9.6	Logger	43
9.6.1	Logger Core Functions.....	43
9.6.2	Active logger Information.....	43
9.6.3	Log Files.....	45
9.6.4	Export the Log Files	46
9.7	Alarms	48
9.7.1	Alarm Settings	48
9.7.2	Activated Alarms.....	49
9.7.3	Alarm History	50
9.8	Communication	51
9.8.1	Ethernet Setting	51
9.8.2	Modbus/RTU Master	52
9.8.3	Modbus/RTU Slave	52
9.8.4	Holding Register Table	53
9.9	System	54
9.9.1	Information & Update	54
9.9.2	User Management.....	57
9.9.3	User Profile	59
9.9.4	Display Settings	60
9.9.5	Audit Trail	62
9.9.6	Support.....	63
9.10	Firmware Update.....	65
9.11	S4C Web offline version	67
9.11.1	Configuration file	67
9.11.2	File verification	68
10	Optional Accessories	69
11	Maintenance	69
12	Disposal of Waste	70
1	Appendix A – Modbus Interface	71
2	Appendix B – Power Consumption of Sensors.....	73
3	Appendix C-Account and permission.....	74

1 Safety Instructions

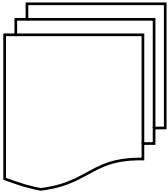

Please check if this instruction manual accords to the product type.

Please observe all notes and instructions indicated in this manual. It contains essential information which have to be observed before and during installation, operation and maintenance. Therefore, this instruction manual has to be read carefully by the technician as well as by the responsible user / qualified personnel.

This instruction manual has to be available at the operation site of the display at any time. In case of any obscurities or questions, regarding this manual or the product, please contact the manufacturer.



WARNING!

Voltage used for supply!

Any contact with energized parts of the product, may lead to a electrical shock which can lead to serious injuries or even death!

- Consider all regulations for electrical installations.
- The system must be disconnected from any power supply during maintenance work.
- Any electrical work on the system is only allowed by authorized qualified personal.



ATTENTION!

Permitted operating parameters!

Observe the permitted operating parameters, any operation exceeding this parameter can lead to malfunctions and may lead to damage on the instrument or the system.

- Do not exceed the permitted operating parameters.
- Make sure the product is operated in its permitted limitations.
- Do not exceed or undercut the permitted storage and operation temperature and pressure.

General safety instructions

- It is not allowed to use the product in explosive areas.
- Please observe the national regulations before/during installation and operation.

Remarks

It is not allowed to disassemble the product.

**ATTENTION!**

Measurement values can be affected by malfunction!

The product must be installed properly and frequently maintained, otherwise it may lead to wrong measurement values, which can lead to wrong results.

Storage and transportation

- Make sure that the transportation temperature of the display and data logger is between -20 ... +60 °C.
- For transportation it is recommended to use the packaging which comes with the display.
- Please make sure that the storage temperature of the display is between -20 ... +70 °C.
- Avoid direct UV and solar radiation during storage.
- For the storage the humidity must be <90%, no condensation.

2 Registered Trademarks

Trademark	Trademark owner
SUTO®	SUTO iTEC
MODBUS®	Modbus Organization, Hopkinton, USA

3 Introduction

The S332 features a 7-inch industrial-grade touchscreen that delivers intuitive, efficient on-site operation. The device integrates seamlessly with the SUTO iTEC sensor portfolio as well as third-party sensors via standard analog or digital communication protocols (Modbus RTU/TCP), enabling comprehensive monitoring of pressure, temperature, dew point, flow, energy consumption, and oil contamination across compressed air systems.

With the browser-based direct configuration capability, the S332 enables real-time data transmission and remote monitoring without requiring proprietary software — streamlining parameter setup, firmware updates, and data retrieval.

4 Features

- Supports connections to SUTO iTEC sensors and third-party sensors.
- 7-inch touch screen for live values and settings.
- Integrated data logger for seamless recording (optional)
- The sensors can be connected via Modbus/RTU, Modbus/TCP, Analog signals, digital signals, and wirelessly with the optional available WTU modules.
- Reading of 150 measurement channels simultaneously via Modbus.
- Integrated web server for remote monitoring and configuration in local area network.
- Fast sensor configurations via web browser-based S4C-Web and via the local display.
- Wall mounting and panel mounting are supported.
- Logger data is safely stored in the S332 and can be exported to local servers or cloud systems.
- Suitable for the food and pharmaceutical industries. (meeting the FDA 21 CFR part 11 requirements)

5 Technical Data

5.1 General

CE	
Display	7" TFT touch display Resolution 1280 x 800
Data logger (Optional)	10 GB, 530 days typical (example: 50 channels @ 1s sampling)
Housing material	PC + ABS
Protection class	IP65
Dimensions	See the dimensional drawing on page 10
Cable entry	3× M20 PG connector (each for 2 cables, Ø5 ... 6 mm) 4× M12 PG connector (each for 1 cable, Ø5 ... 6 mm)
Weight	1... 1.8 KG (depending on the installed options and housing)

5.2 Electrical Data

Power supply	85 ... 305 VAC, 60 W, 50/60 Hz (AC version)
	18 ... 30 VDC Max. 7 A (DC version)
Sensor supply	Maximum 50 W (AC version)
	Maximum 150 W (DC version, see section 8.3 and 8.7 for details)

5.3 Input-Signals

Modbus signal input	1 x Modbus/RTU(Master) 1 x Modbus/TCP(Master) (Recommended to not exceed 150 channels for logging performance)
Analog input (Optional)	0 ... 20 mA/4 ... 20 mA, 0 ... 10 V/0.5 ... 4.5 V Up to 2 Analog input modules, each module has 4 Analog input channels.
Digital input (Optional)	Up to 2 digital input modules, each module has 4 digital input channels.

5.4 Output-Signals

Alarm output	Built-in 2 Relay rating, rating: 3A 230 VAC / 3A 30 VDC 2 relay modules (Optional). Each module has 4 relays
--------------	---

	rating: 3A 230 VAC / 3A 30 VDC
Modbus signal output	1 x Modbus/RTU (Slave) 1 x Modbus/TCP (Slave)

5.5 Data Interface

Connection	Ethernet (Modbus/TCP Master/Slave & Web-Server) RS-485 (Modbus/RTU Master/Slave) USB-C (Data export)
------------	--

5.6 Environment Data

Operating temperature	0 ... +45 °C
Operating humidity	<90%, no condensation
Transportation temperature	-20 ... +60 °C
Storage temperature	-20 ... +70 °C

6 Dimension and Installation

Wall mounting:

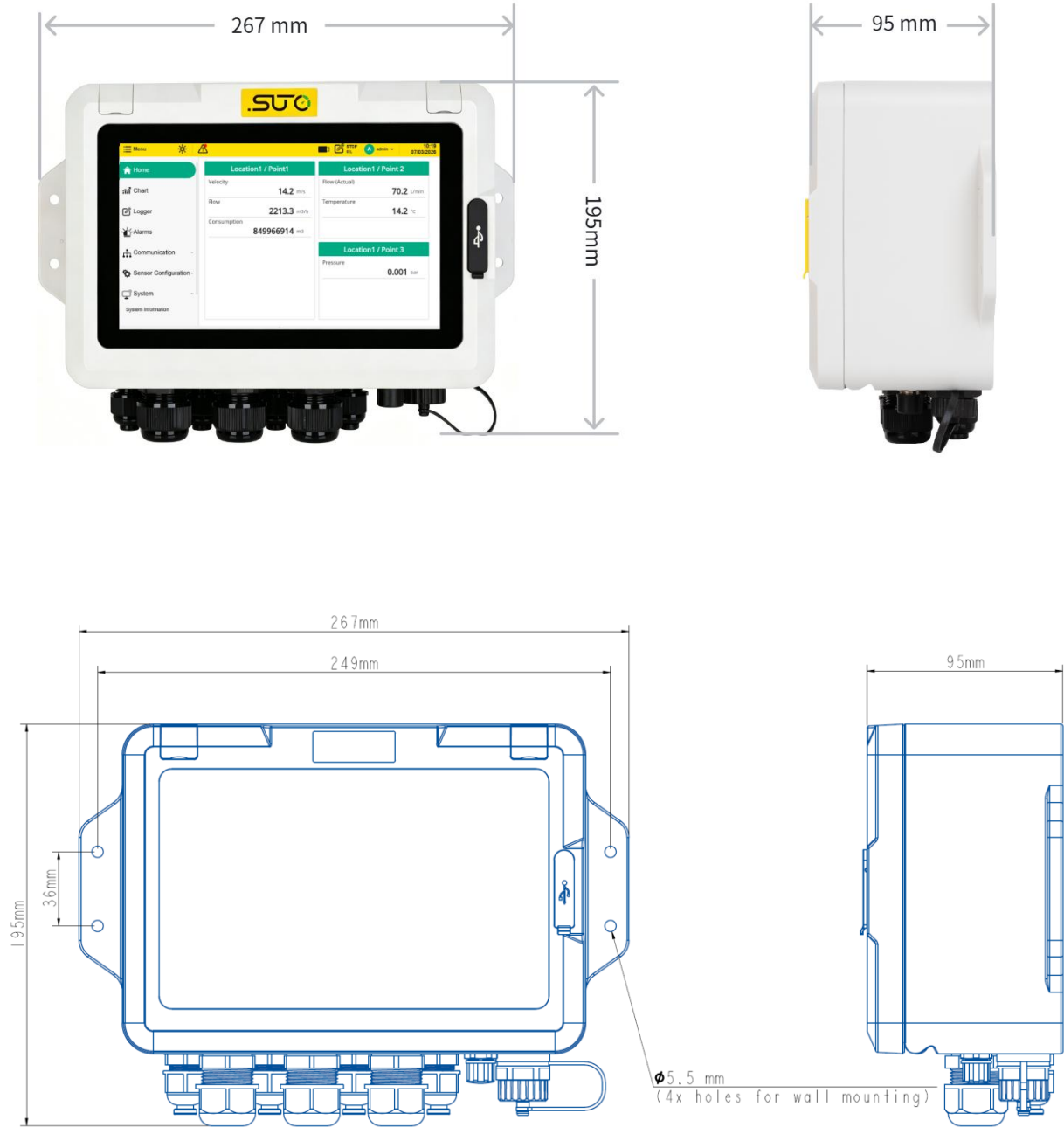

Panel mounting:

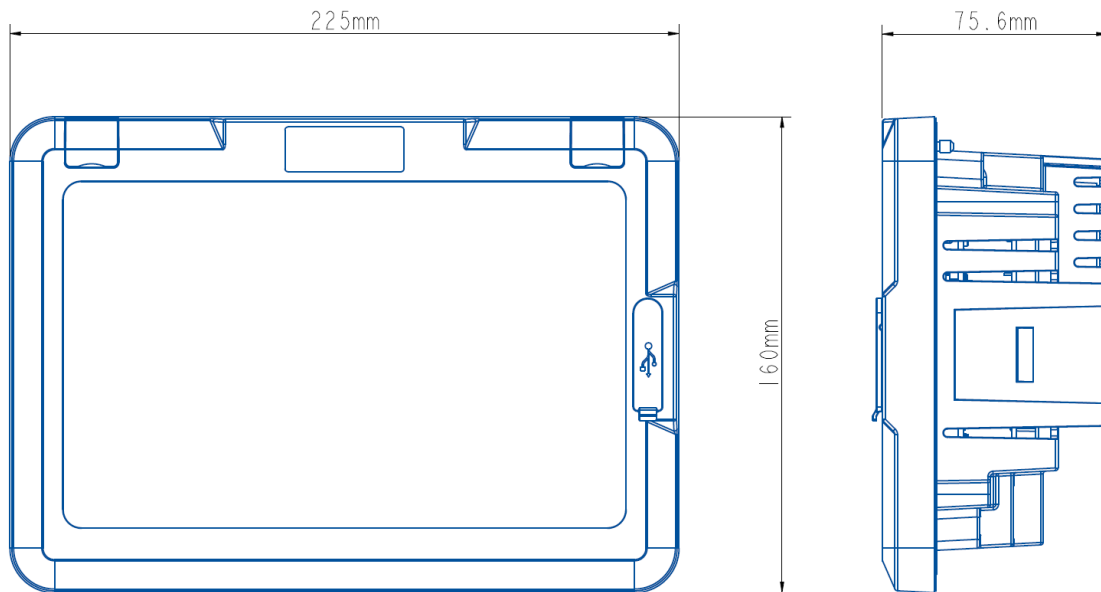

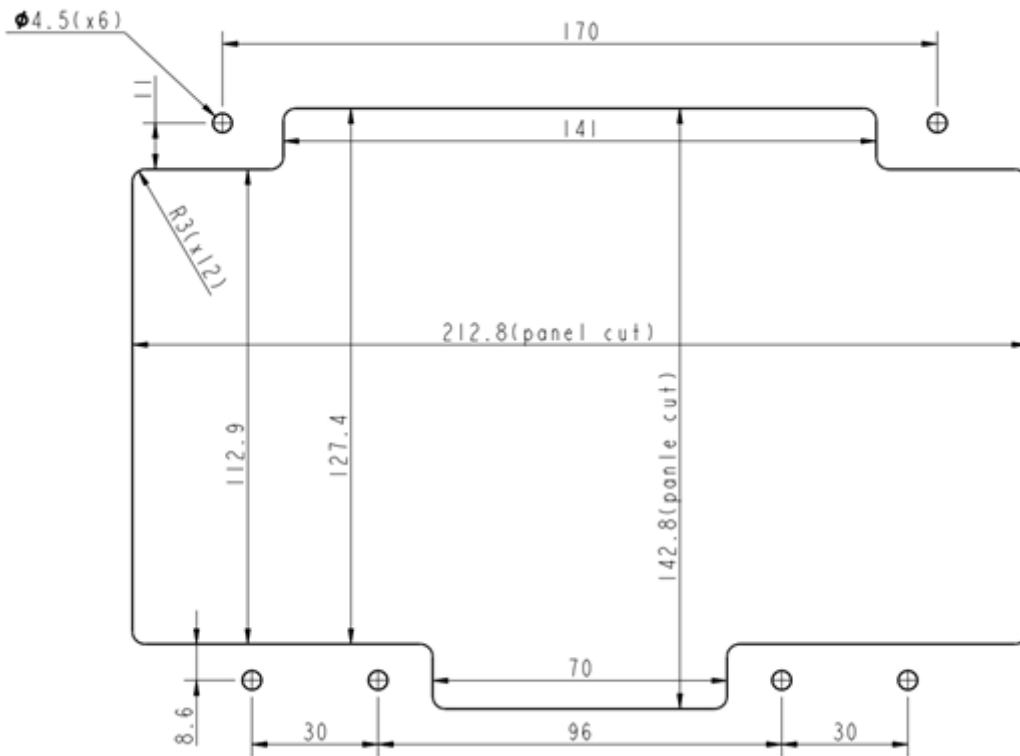

ATTENTION!

Install the product in strict compliance with its applicable environmental parameters! Avoid strong interference sources around the equipment, as this may affect the communication between the product and other devices!

7 Installation

Please make sure that all components listed below are included in your package.

Qty	Description	Item No.
1	S332 Display*	D500 3321/ D500 3322/ D500 3323/ D500 3324
1	Instruction manual	
* The following items are optional		
1	Data Logger, 10 GB Memory	A3001
1	Analog Input Module, 4 Channels, Current: 0/4...20 mA	A3003
1	Analog Input Module, 4 Channels, Voltage: 0...10 V / 0.5...4.5 V	A3004
1	Digital Input Module, 4 Channels	A3005
1	Alarm Relay Module, 4 Relays, Rating: 3A 230 VAC / 3A 30 VDC	A3006

7.1 Installation Requirements

The S332 is for indoor use only! At an outdoor installation, the device must be protected from solar radiation and rain.
It is strongly recommended not to install S332 permanently in a wet environment.

7.2 Safety Instructions



Danger!
Mains voltage!
Contact with live parts may cause damage to the product or personal injury!

All electrical installation work must be carried out in full compliance with applicable national and international standards and regulations (e.g. VDE 0100).
All electrical work must be performed only by qualified and skilled personnel with appropriate electrical training and authorization.

7.2.1 Protective Grounding



WARNING!
Risk of electric shock and electromagnetic interference!

The device must be reliably connected to a protective earth (ground) in strict accordance with the installation specifications provided in this manual. Failure to establish a proper ground connection may result in:

- Electromagnetic interference (EMI) affects measurement accuracy and device performance.
- Malfunction or permanent damage to the device.
- Risk of electric shock to operators upon contact with the device enclosure.
- Grounding must be verified prior to initial power-up and re-checked during periodic maintenance.

7.2.2 Overcurrent Protection — AC Version Only



WARNING!

Overload and Short-Circuit Hazard!

A circuit breaker must be installed in the supply line to the device to provide protection against:

- Overload conditions
- Short circuits
- Other electrical faults

Installation requirements of the circuit breaker:

- The current rating of the circuit breaker must match the device's rated operating power as specified in the product's technical data section.
- The circuit breaker must comply with IEC 60947.
- The circuit breaker must be installed in the supply line ahead of the device (i.e., between the power source and the device).

8 Electrical Connections

Connectors Layout

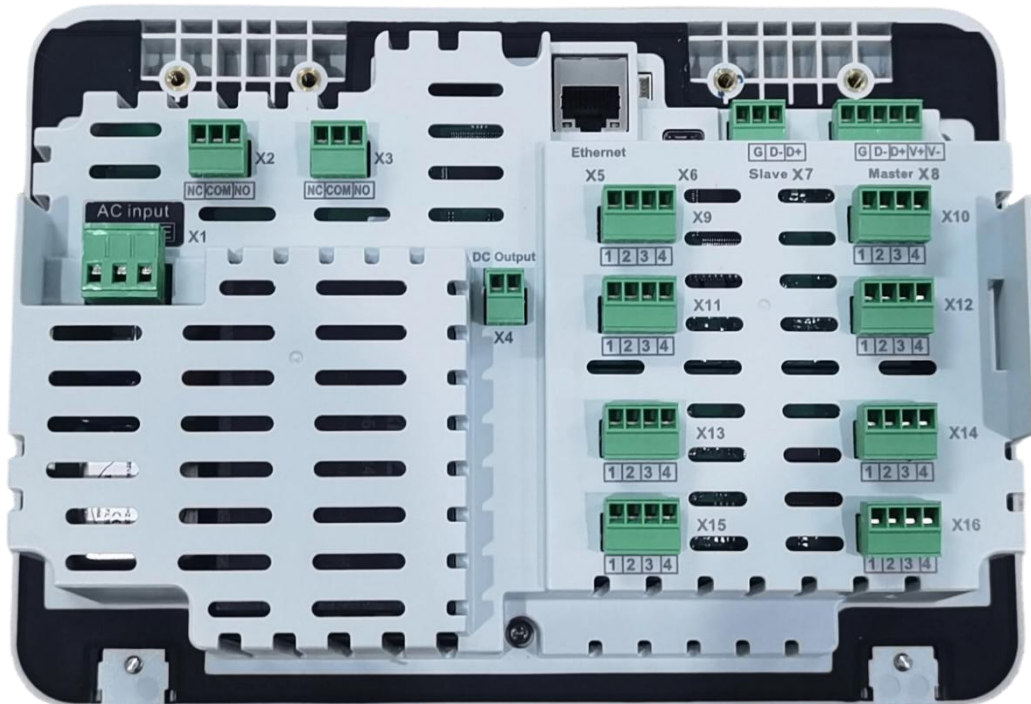

X1	Power supply
X2	Built-in relay 1
X3	Built-in relay 2
X4	DC power supply output
X5	Ethernet
X6	Reserved
X7	RS485 (Slave), to connect S332 to a Modbus/RTU master
X8	RS485 (Master), to connect S332 with Modbus/RTU sensors
X9...X16	Terminals for analog/digital/relay module (Optional)

Please find the details about these connections in the below chapters.

8.1 Power Supply Connection (X1)

AC power version, 85 ... 305 VAC, 50/60 Hz

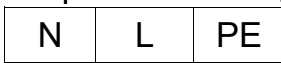

DC power version, 18 ... 30 VDC

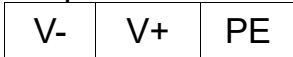

8.2 Relay Output Connection (X2, X3)

The S332 features two built-in output relays (Relay 1 and Relay 2). Relay 1 is connected via terminal X2, and Relay 2 via terminal X3. The electrical ratings of the relay contacts are listed below.

3 A @ 230 VAC

3 A @ 30 VDC

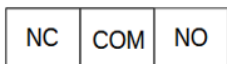

NC: Normally Closed contact
 COM: Common contact
 NO: Normally Open contact

Contact Status:

The NC–COM circuit is closed in the event of power loss or alarm activation.

See the table below for the relay states.

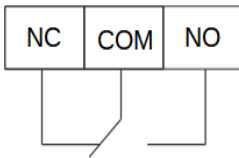
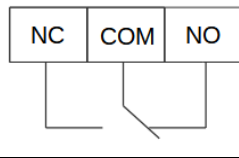
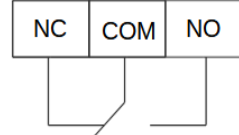
State of the S332	Relay states
The S332 is powered off.	
The S332 is powered on.	
The alarm is activated. (set alarm threshold reached)	

The example shows a DC alarm unit wiring.
 (When an alarm occurs, the alarm unit should be activated.)

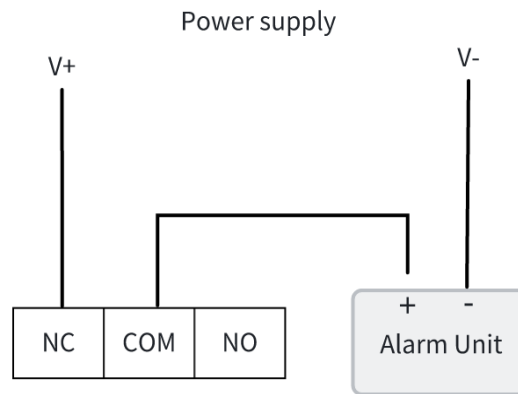

8.3 Power Output Connection (X4)

V-	V+
----	----

DC power output. This terminal provides power to the connected sensor.

AC version: Maximum 50 W (AC version)

DC version: Maximum 150 W, it base on the input power supply, DC power output (W)= total device power(W)-15 W

Please note that the total DC power output is shared with the X8 Modbus Master connector and optional Analog input modules. The power demand of the connected devices on the X4 + X8 + Analog input module cannot exceed the above-mentioned figure.

8.4 Ethernet Connection (X5)

Through the Ethernet connector, the S332 can be connected to the TCP/IP network over the Modbus/TCP protocol.



RJ-45 connector

This port is connected by internal cable to the bottom port, just use the bottom one for connector.

8.5 Modbus Slave (X7)

G	D-	D+
---	----	----

G: GND for Modbus

D-: Data -

D+: Data +

8.6 Modbus Master (X8)

8.6.1 Pin Assignment

When the S332 connects to the sensor via Modbus communication (X8), It can also supply power to the sensor. For the AC version, the maximum is 50 W; for the DC version, it base on the input power supply, up to 158 W.

Note: Both the DC power output terminal (X4) and the Modbus Master terminal (X8) can provide DC power output. The combined output adopts the same power limit as single terminal output.

Power output (X4)	AC version: Maximum 50 W (AC version)
Power output (X8)	DC version: Maximum 150 W, it base on the input power supply, DC power output (W)= total device power(W)-15 W
Combined power output (X4+X8)	Please note that the total DC power output is shared with the X8 Modbus Master connector and optional Analog output modules. The power demand of the connected devices on the X4 + X8 + Analog input module cannot exceed the above-mentioned figure.

G	D-	D+	V+	V-
---	----	----	----	----

G: GND for Modbus
 D-: Data -
 D+: Data +
 V+: Positive power supply
 V-: Negative power supply

8.6.2 Connection between S332 and SUTO iTEC Sensor

X8	S230 S231	S220 S211 S215	S401 S421 S430	S451 S453	S423 S403	S435	S415 S418 S418V
Terminal	Pin	Pin	Pin	Terminal	Pin	Terminal	Pin
G	6	N/A	B.1	2	A.1	N/A	N/A
D-	5	A.5	B.5	7	A.5	RS485(B)	A.1
D+	4	A.4	B.4	6	A.4	RS485(A)	A.4
V+	3	A.3	B.3	3	A.3	DC+	A.3
V-	2	A.2	B.2	4	A.2	DC-	A.2

X8	S402 (A1416)	S402 (A1418)	S120 S130 S132	S461	S462	S011	S111
Terminal	Pin	Pin	Pin	Pin	Pin	Pin	Terminal
G	1	N/A	N/A	1	N/A	N/A	N/A
D-	5	4	A.5 / C.5	5	5	5	B
D+	4	2	A.4 / C.4	4	4	4	A
V+	3	1	A.3 / B.3	3	3	3	12
V-	2	3	A.2 / B.2	2	2	2	11

Note: For S120 with display version, the A.4 and A.5 are not available!

For other third-party sensors, please refer to the terminal and its function definition for wiring operations.

8.6.3 Modbus/RTU Cable Length

A Modbus/RTU bus line has limitations which shall not be exceeded, otherwise the communication might not be stable.

- The maximum total bus length must not exceed 1200 m.
- The stub length to each node must not exceed 30 cm.

See the picture below for details.

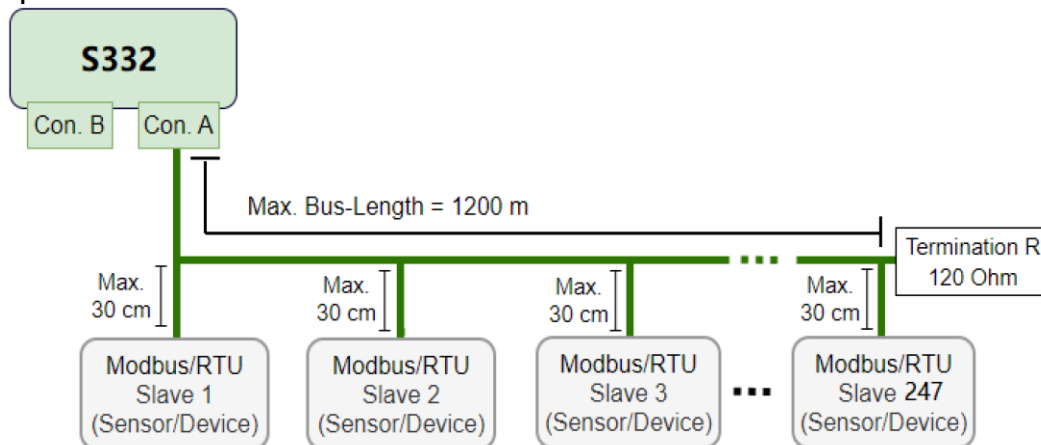

8.6.4 Modbus/RTU Wiring and Cable Specifications

To ensure a stable communication a twisted-pair bus cable must be chosen to set up the Modbus/RTU communication.

Bus-cable specifications must follow:

- Cable specification: 2 x 2 x 0.22 mm², Li-2YCY (A553 0123), complying with EIA-485 standard.

- The shield must be connected at one end to the master GND connection.
- At the end of the bus, a 120 Ohm resistor should be placed a termination resistor.

See the below picture for details.

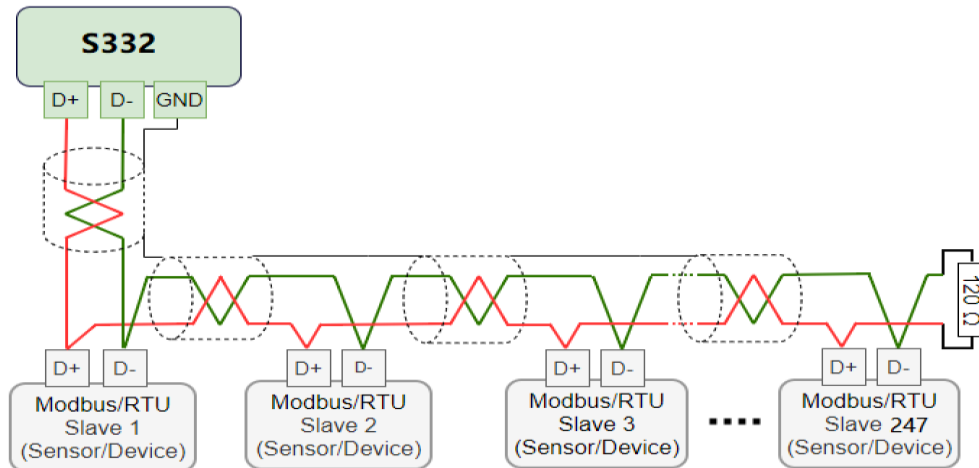

8.6.5 Daisy-Chain Configuration using RS-485 Splitter

M12 Connector Devices

SUTO iTEC devices with M12 connectors can be connected to a Modbus/RTU daisy-chain configuration using the following accessories:

RS-485 Splitter: Enables daisy-chain connection of M12 devices	A554 3310
Termination Resistor: Bus termination (install at last splitter)	C219 0055

See example below for reference.

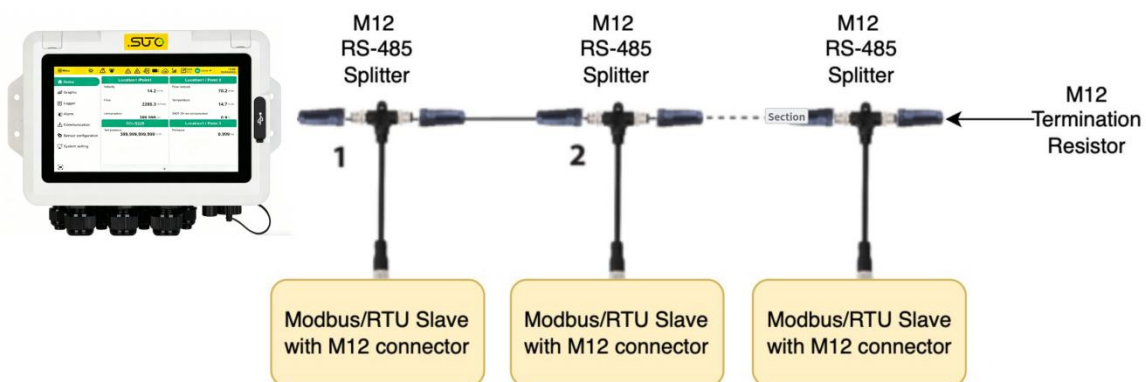

M8 Connector Devices

To connect SUTO iTEC devices with M8 connectors to the daisy-chain, the following accessories are required:

RS-485 Splitter: Provides daisy-chain connection points	A554 3310
M8 to M12 Converter Cable: Adapter for M8 device integration	A553 0161
Termination Resistor: Bus termination (install at last splitter)	C219 0055

See example below for reference.

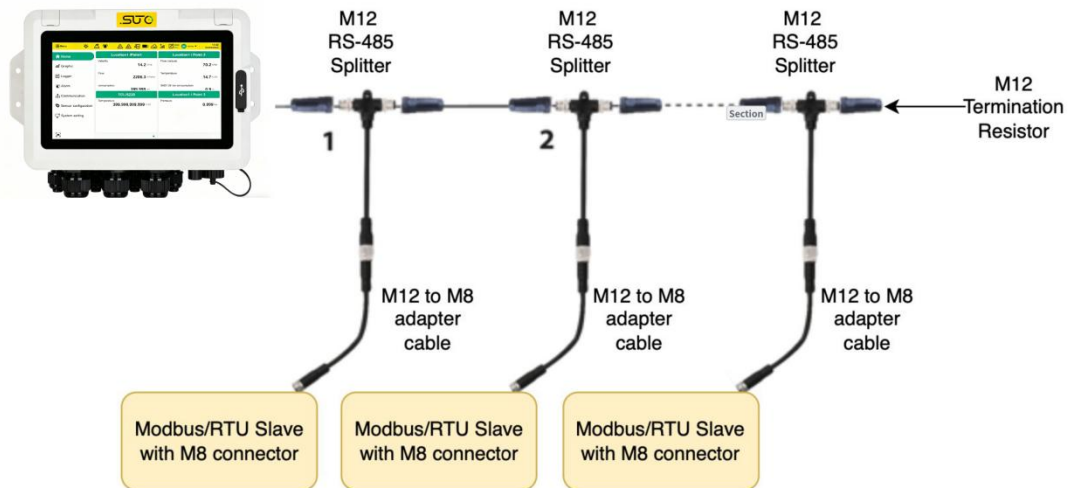

8.7 Analog / Digital / Relays Module Connection (X9...X16)

The X9...X16 terminals are provided whenever an option module is installed. These can be analogue, digital and/or relay modules. Each module has four channels. A maximum of two modules can be installed; any combination is possible. Connectors X9 to X12 are for one installed module, and channels X13 to X16 are for the other installed module.

8.7.1 Analog Input Connection (Option Module)

Terminal	Pin	Signal (0 ... 20 mA / 4 ... 20 mA)	Signal (0 ... 10 V / 0.5 ... 4.5 V)
X9...X12/ X13...X16	1	V-	V-
	2	V+	V+
	3	I+	E+
	4	I-	E-

Legend to pin assignment

V+	Negative sensor supply
V-	Positive sensor supply
I+	Positive analog signal
I-	Negative analog signal
E+	Positive voltage input
E-	Negative voltage input

The wiring diagrams below show how to connect 2-wire, 3-wire and 4-wire sensors with option modules.

In these diagrams:

V+ stands for power + (24 VDC)

V- stands for power – (24 VDC)

S+ stands for Signal +, for example 4 ... 20 mA +; 0.5 V ... 4.5 V +.

S- stands for Signal -, for example 4 ... 20 mA -; 0.5 V ... 4.5 V -.

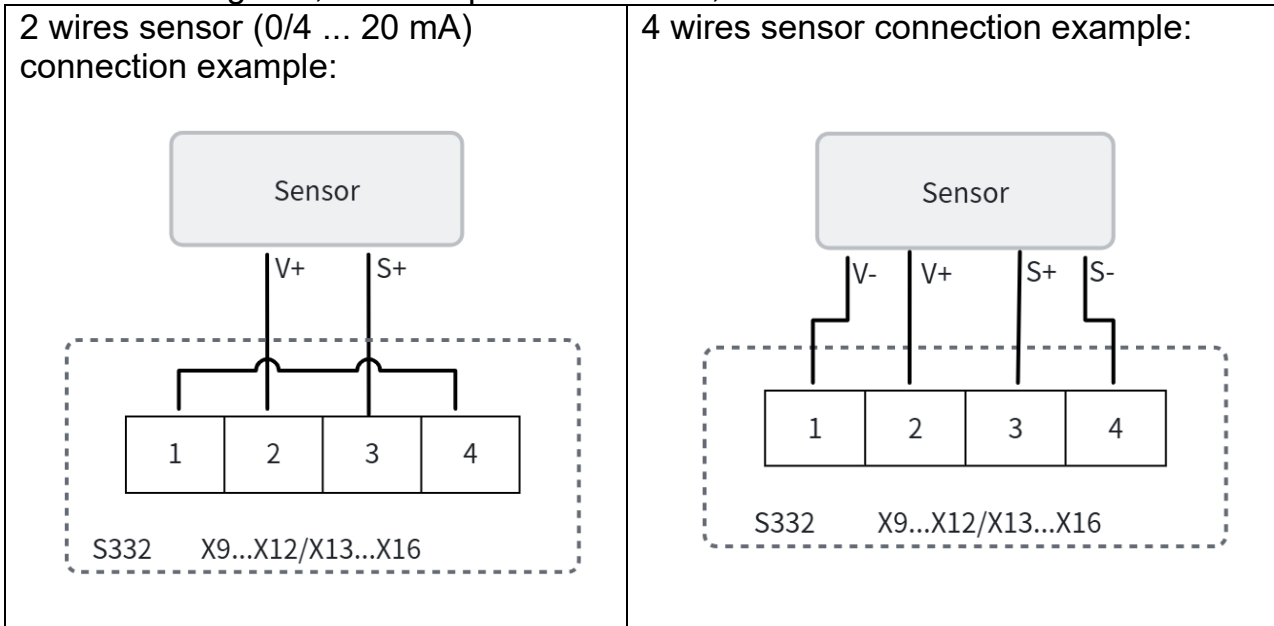

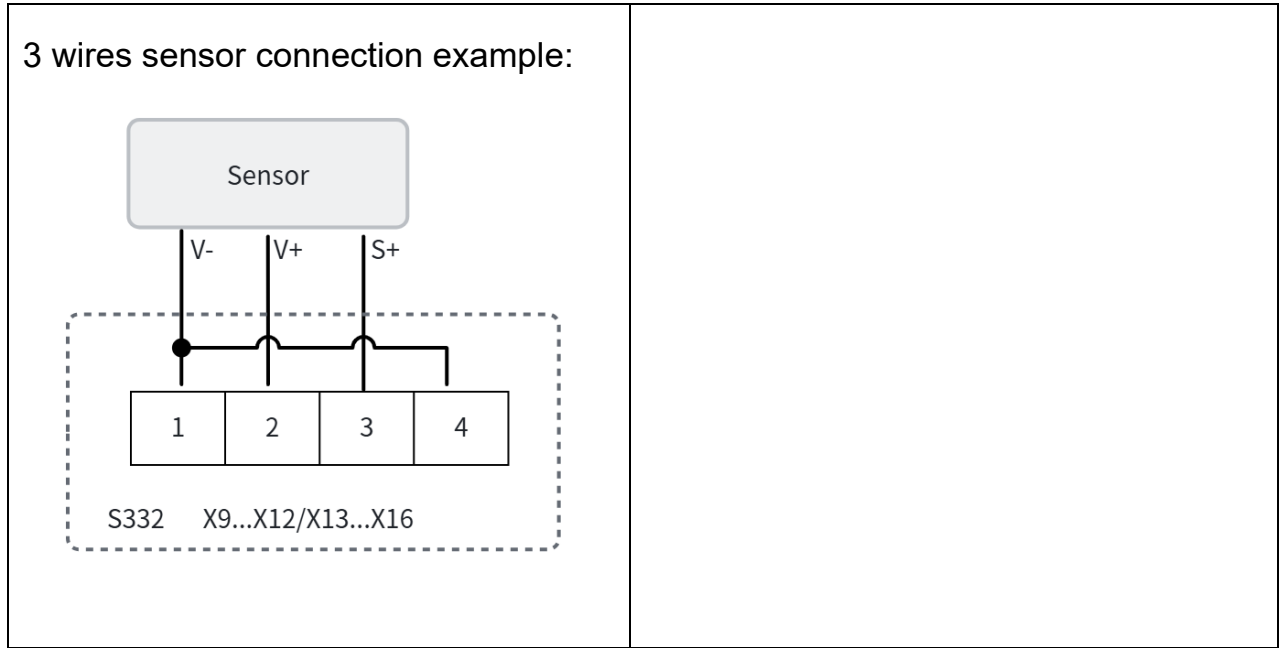

8.7.2 Digital Input Connection (Option Module)

Terminal	Pin	Signal	Description
X9...X12/ X13...X16	1	V-	Negative sensor supply
	2	V+	Positive sensor supply (24 VDC)
	3	P+	Positive pulse input
	4	P-	Negative pulse input

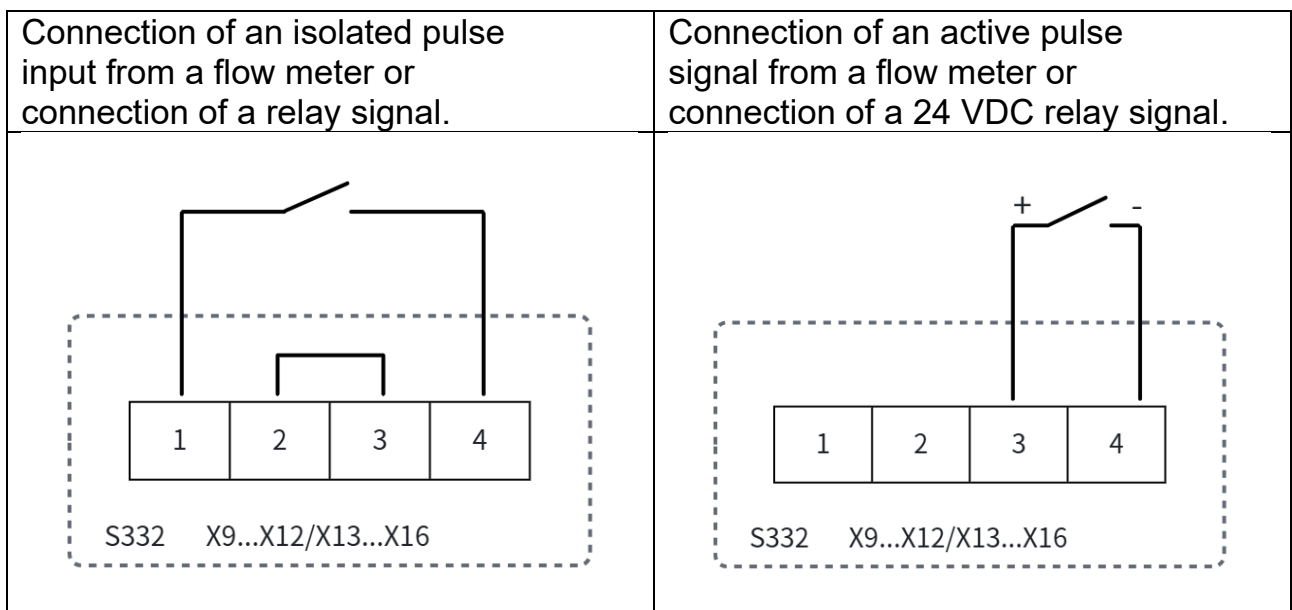

Note: Only signal wiring shown above. Sensor power can be supplied by S332 (terminal 1 and 2) or external independent power source.

8.7.3 Relay Module Connection (Option Module)

Relay contact rating

The relay contacts are rated for the following loads:

Parameter	Rating
AC switching capacity	3 A @ 230 VAC
DC switching capacity	3 A @ 30 VDC

Relay Terminal Assignment

Terminal	Pin	Description
X9...X12/ X13...X16	1	NC (Normally closed)
	2	COM (Common ground)
	3	NO (Normally open)

Note:

The NC, COM contacts are closed under the following conditions:

1. Device is in a powered-off state.
2. Alarm condition has been triggered (configured threshold reached).

9 Operation

The S332 supports two operation methods:

- Local operation via touchscreen display
- Remote operation via S4C Web interface

9.1 S4C Web Interface

S4C Web Interface is the browser-based interface for S332, providing monitoring and control capabilities. Users can access real-time measurement data and configure the S332 remotely via web browser.

Access S4C Web

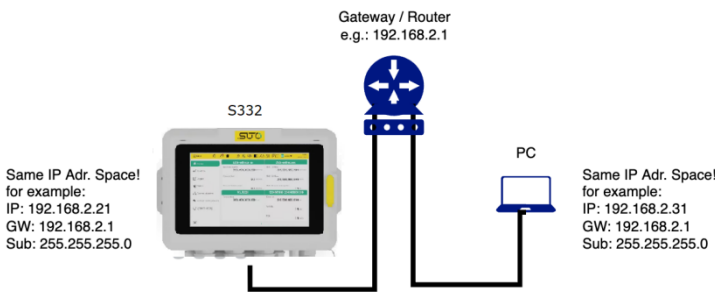

1. Establish network connection between PC and S332. Both devices must be on the same LAN.

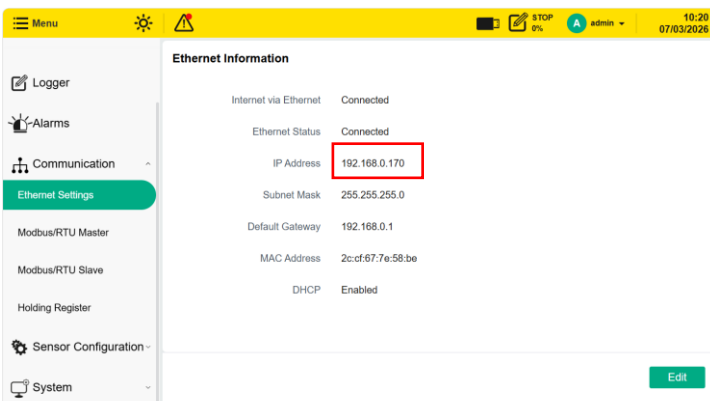

2. Navigate to **Communication > Ethernet Settings** to retrieve S332 IP address.

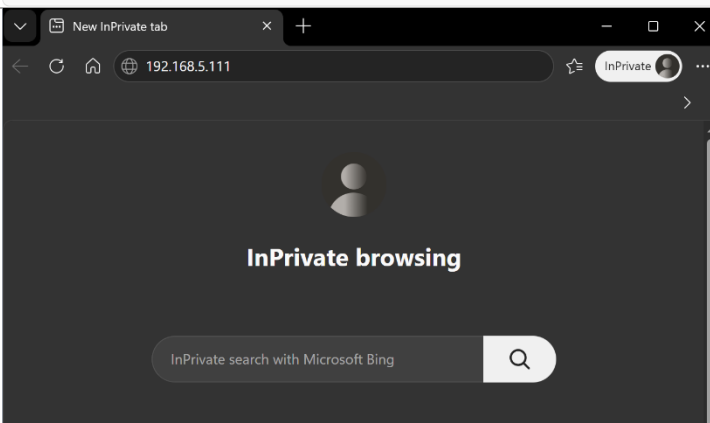

3. Open the browser and enter the S332 IP address in the address bar.

Note: Google Chrome is recommended for optimal performance.

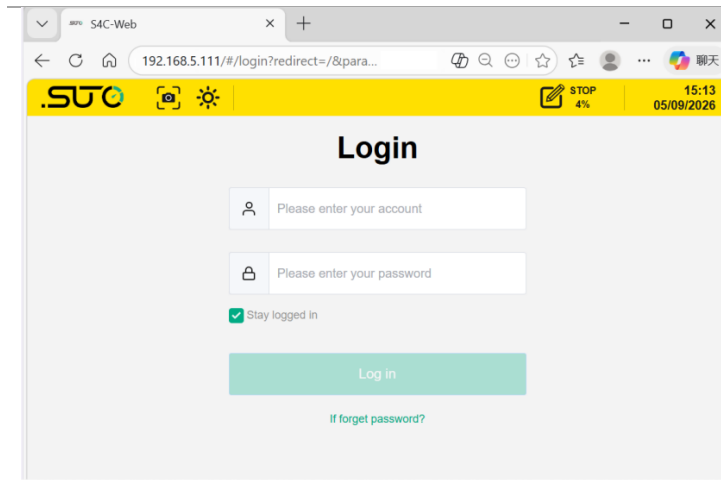

4. Login page will be displayed.

The S332 and S4C Web operate identically. The following sections demonstrate operations using the S332 display—these steps apply to both models.

9.2 Login

Upon power-up, S332 automatically displays the login page.

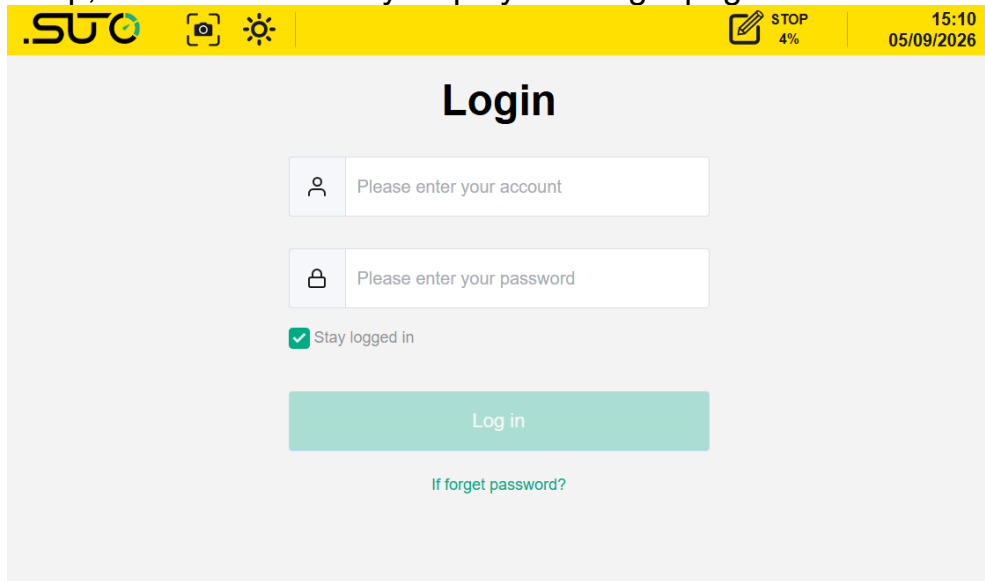

Startup and Login

After the S332 is powered on, it automatically enters the system login page.

Factory-Default Account

- Username: admin
- Password: 123456

Security Notice:

Change the default password immediately after your first login via system>User profil.

Password Recovery:

If you have forgotten your password, the reset process differs by account type:

1. Non-administrator accounts

The admin account of S332 can reset passwords for other accounts. Please login with the admin account and reset the user password in the account settings for that particular account.

2. Administrator accounts

Click [If forget password?](#) button, then input the admin account, you can see the machine ID and device serial number, then send these details to SUTO iTEC, and you will receive a security code to complete the password reset.

9.3 Sensor Configuration

Configure all sensors before commissioning the system. Match each sensor configuration to the actual sensor models you will use—this ensures accurate data acquisition and display.



IMPORTANT!

After adding, editing, or deleting sensors, click **Save** to device to confirm your changes. Any unsaved changes will be lost.



ATTENTION!

After adding sensors, go to **Live-View Layout** to assign each channel to a location and measurement point. Sensor data will not be displayed until this step is completed.

9.3.1 SUTO iTEC Sensor

Configuration Procedure

1. Click **Sensor Configuration > SUTO iTEC Sensor**.

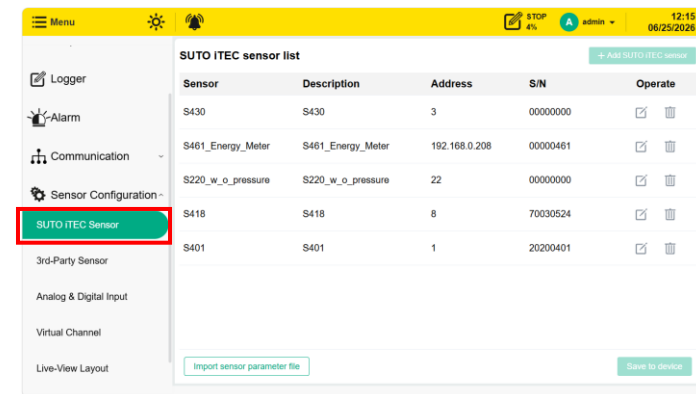

2. Click **+Add SUTO iTEC sensor** in the top right corner.

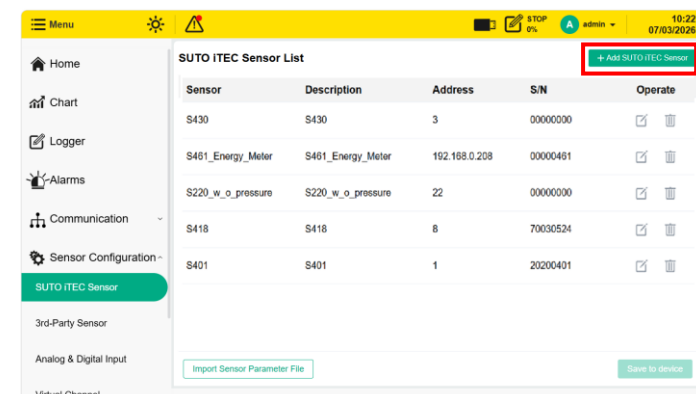

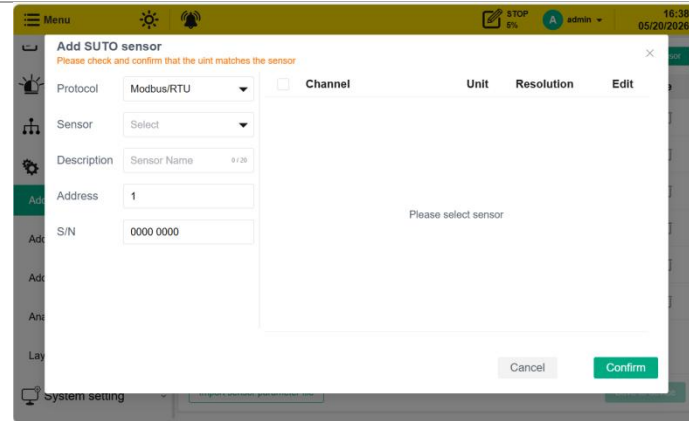

3. The editing pop-up window appears.

- In the left section of the dialog, select the Protocol type and Target sensor model that match your sensor.
- Select any other required fields as needed.
- Click OK to confirm.

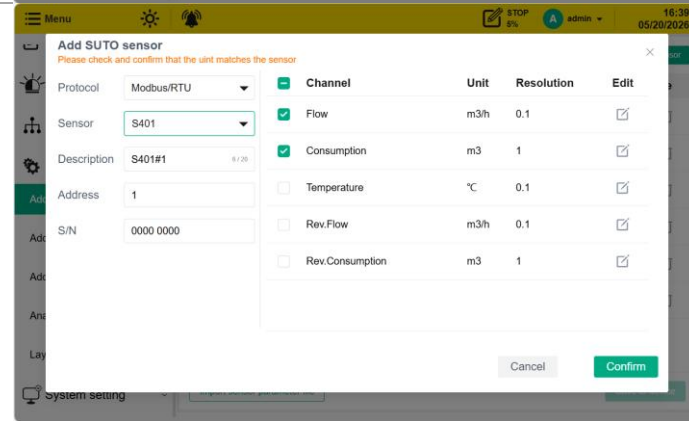

4. In the right section, the default configuration of the sensor is displayed. Please edit the channel information according to the actual parameters of the sensor.

Note: Click Edit icon to edit channel information.

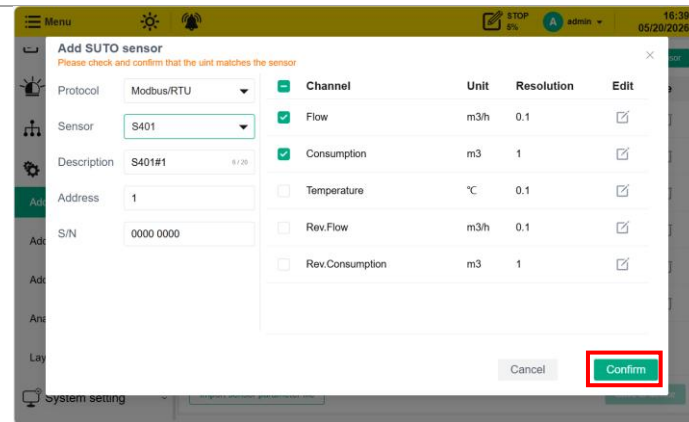

5. Click **Confirm** to apply the settings.

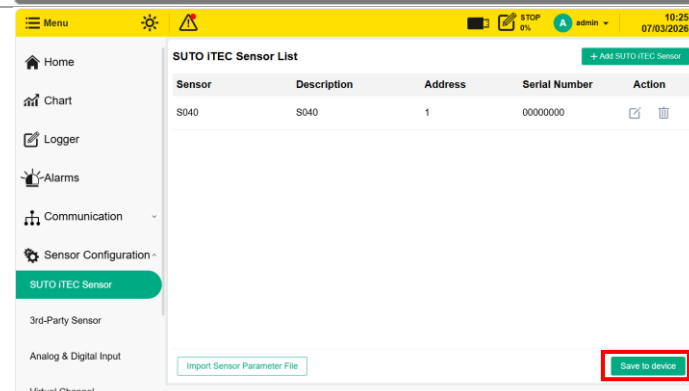

6. The sensor is now displayed in the SUTO iTEC sensor list. Click **Save to Device** to confirm adding the sensor.



Click this icon to edit the sensor information



Click this icon to remove sensor from the device.

Note: The Modbus communication parameters can be set in the **Communication** Menu.

For sensors connected to the S332 via the Modbus RTU protocol, configure the relevant parameters in the **Communication>Modbus/RTU Master**. Please note that these parameters must be set identically to those of the connected sensors. A mismatch in communication parameters will cause the communication to fail. The Master (S332) and all Slaves (Sensors) must have the same communication parameters.

9.3.2 3rd-Party Sensor Configuration Procedure

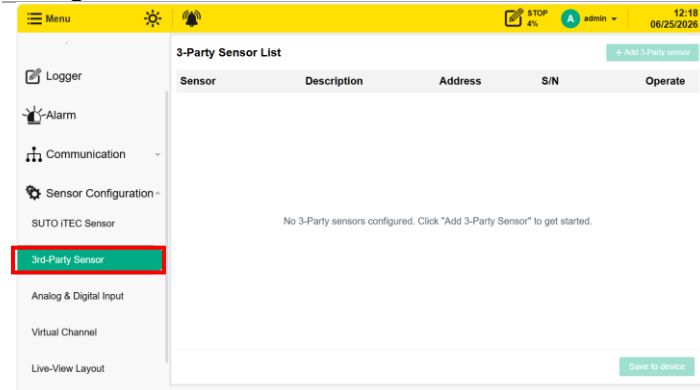

1. Click **Sensor Configuration > 3rd-Party Sensor**

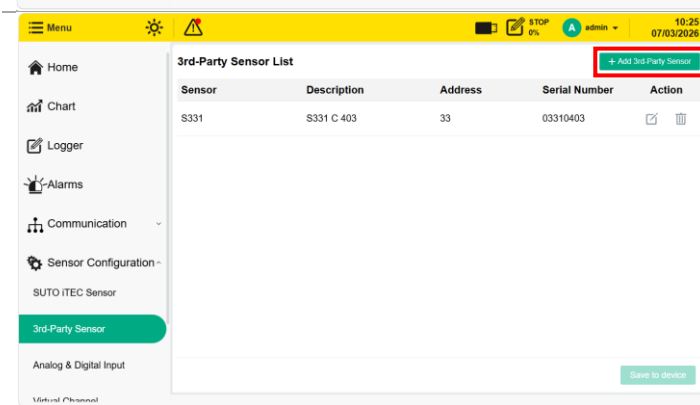

2. Click **+Add 3-party sensor**.

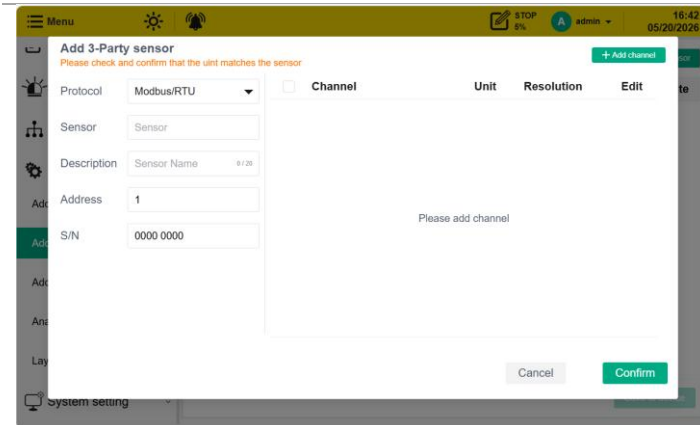

3. The editing pop-up window appears. In the dialog left panel, select protocol type, sensor model etc.

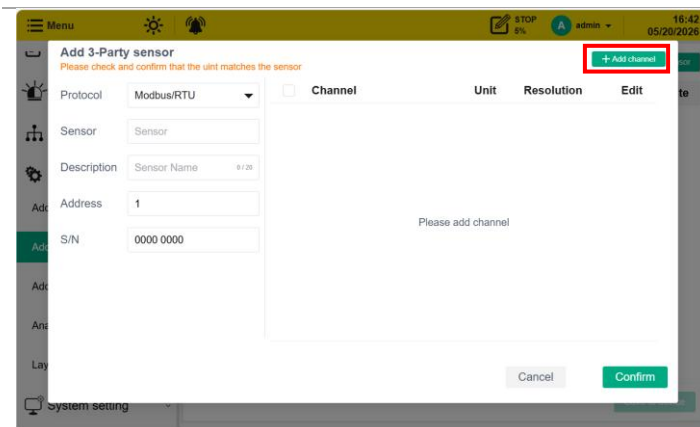

4. Click **+Add channel** to add channel and enter the required channel information.

Note: Please fill in the channel information **correctly**, as this will affect data transmission and reading.

Repeat as needed for multiple channels.

For more information, please refer to the instruction manual of the third-party sensor, where the details for modbus communication should be listed.

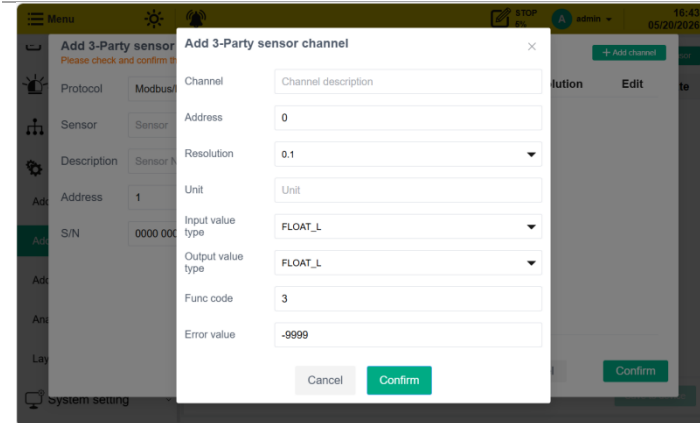

5. Click **Confirm** to finalize sensor and channel configuration.

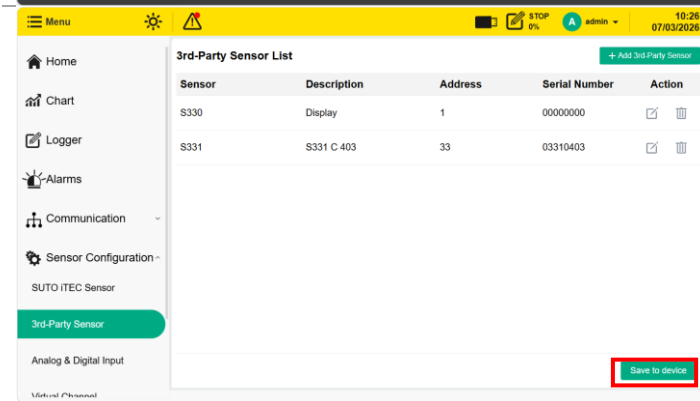

6. Click **Save to Device** to commit settings.

9.3.3 Analog & Digital Input

1. Click **Sensor Configuration > Analog & Digital Input** on the Menu bar.

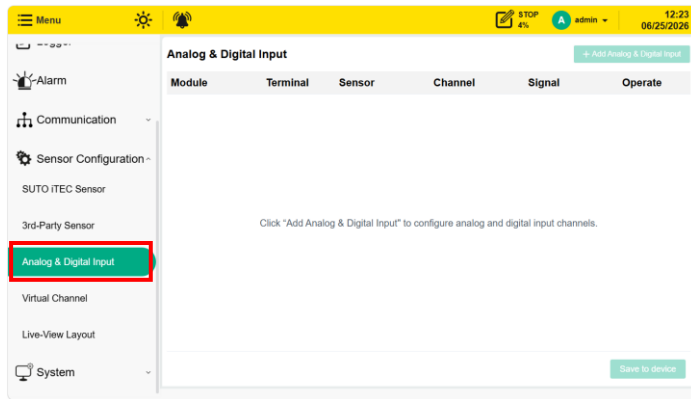

2. Click **+Add Analog & Digital Input**, A pop-up will appear.

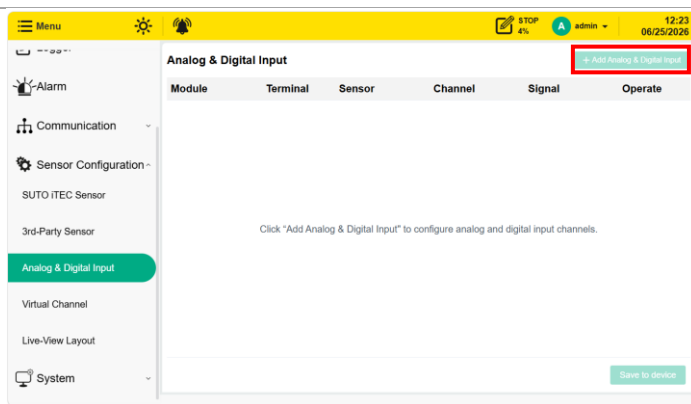

3. In the pop-up, configure the sensor and channel parameters.

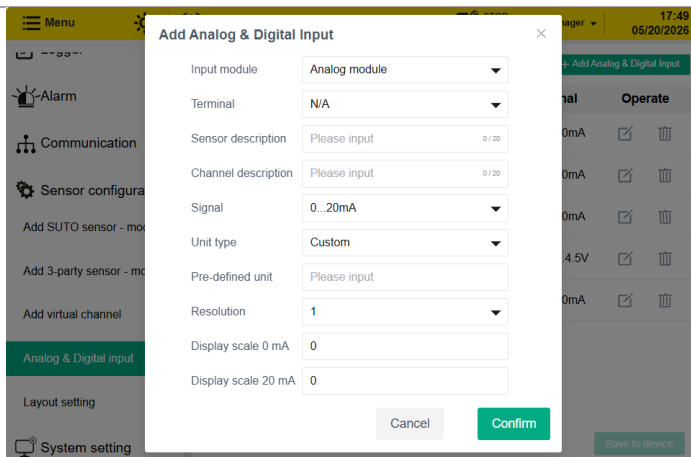

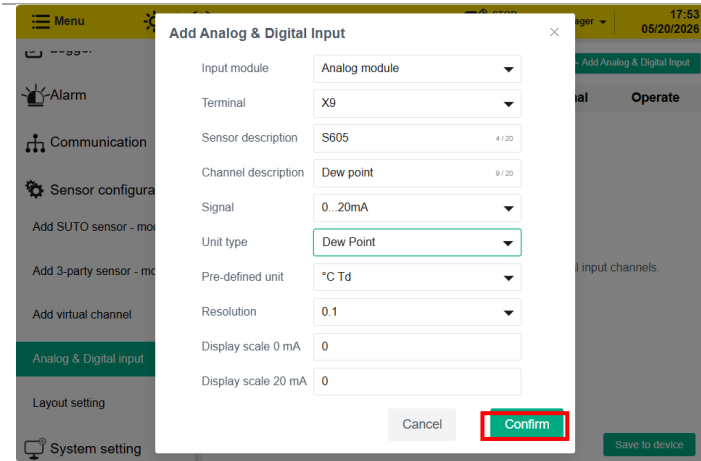

4. Click **Confirm** to return to the list of Analog & digital input.

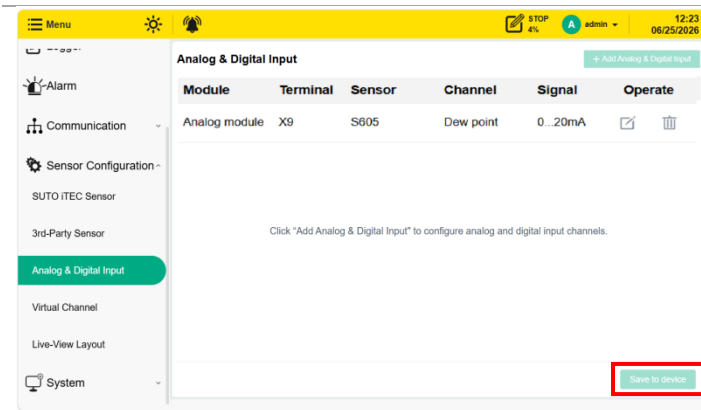

5. The newly created channel now appears in the list. Click **Save to device** to commit settings.



Click this icon to edit the sensor information



Click this icon to remove sensor from the device.

Note:

The system automatically detects installed input modules. All installed modules are available in the Input Module drop down menu. Corresponding terminal numbers will be automatically populated based on the selected module.

9.3.4 Virtual Channel Configuration Procedure

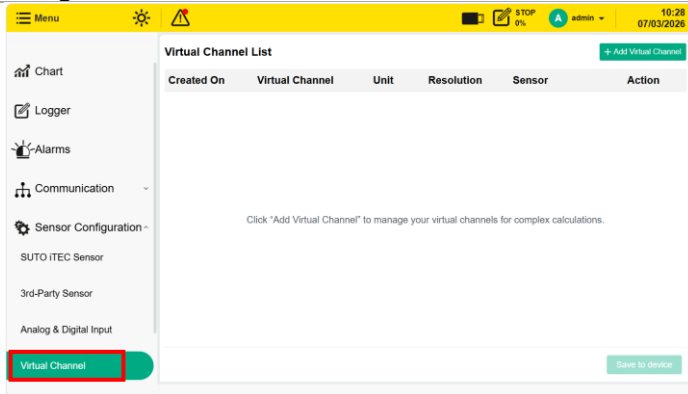

1. Click **Sensor Configuration > Virtual Channel** on the Menu bar.

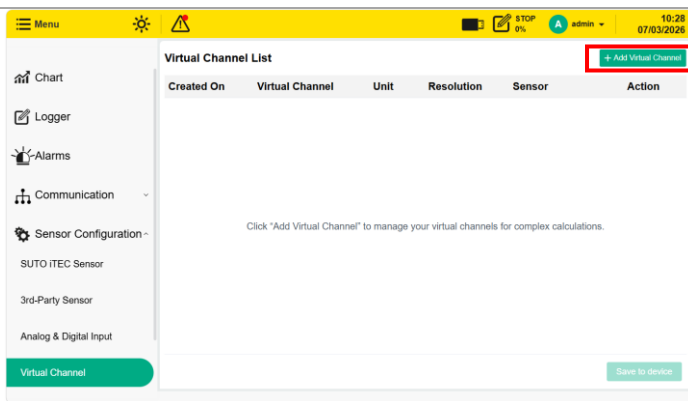

2. Click **+ Add Virtual Channel** button, A pop-up will appear.

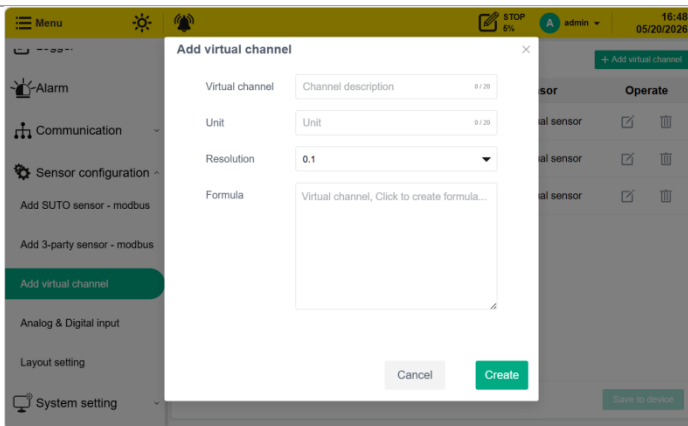

3. In the pop-up, fill in the basic parameters of the virtual channel, such as channel name, unit and resolution. Click the **Formula** input area to open the formula editing pop-up.

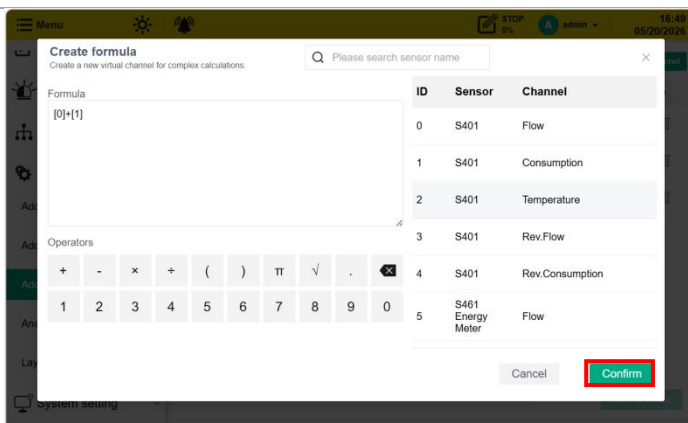

4. In the formula pop-up, you can use standard operators and existing channels to edit the formula. Click **Confirm** after completing the formula editing.

Note:

- Ensure the formula is logically valid when configuring it, invalid formulas will cause the formula creation to fail.
- The name of each virtual channel must be unique to avoid conflicts with existing physical channels or virtual channels.

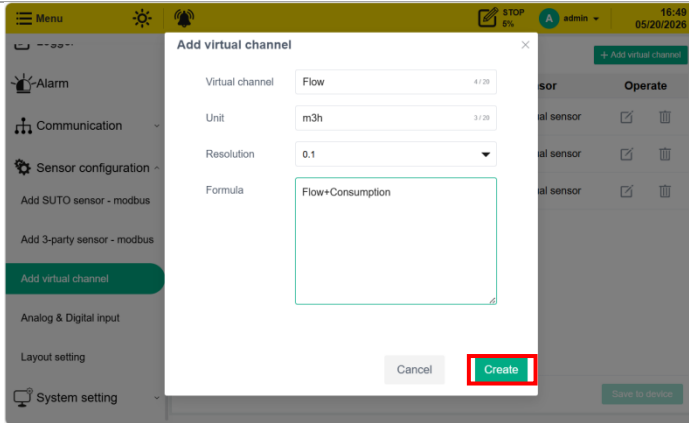

5. After confirmation, it will return to the **Add Virtual Channel** pop-up. Check the input information and click **Create**.

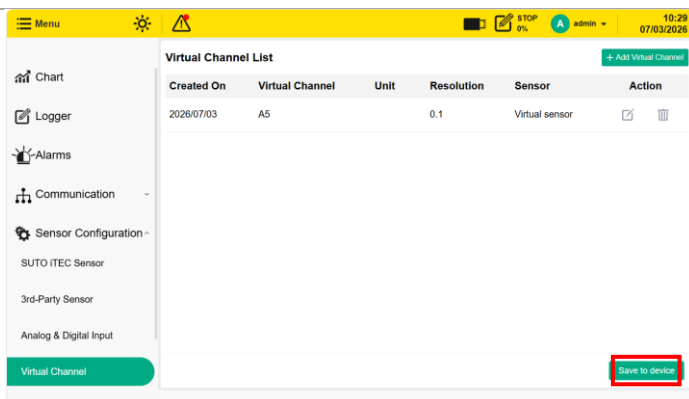

6. The created virtual channel now appears in Virtual Channel List. Click **Save to Device** to commit settings.

9.3.5 Live-View Layout

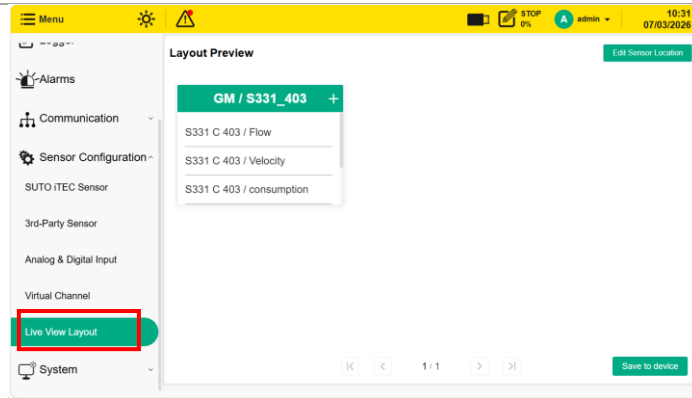

1. Click **Sensor Configuration> Live View Layout**

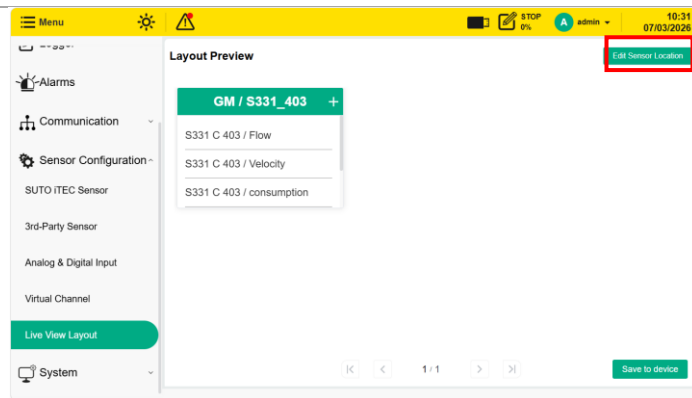

2. Click **Edit sensor location** button

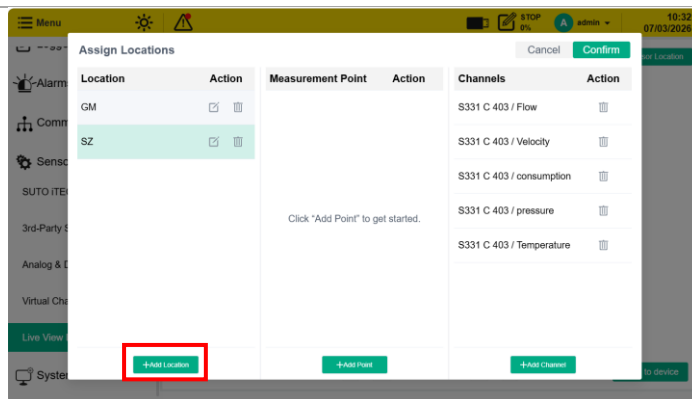

3. A pop-up window appears. Click **+Add Location** button to add the measurement location

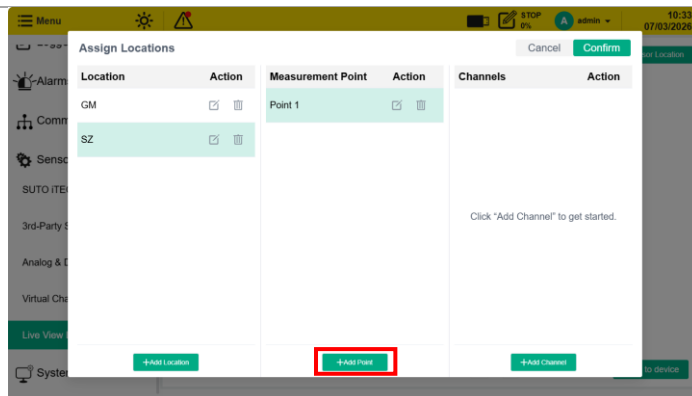

4. Click **+Add point** button to add the measurement point

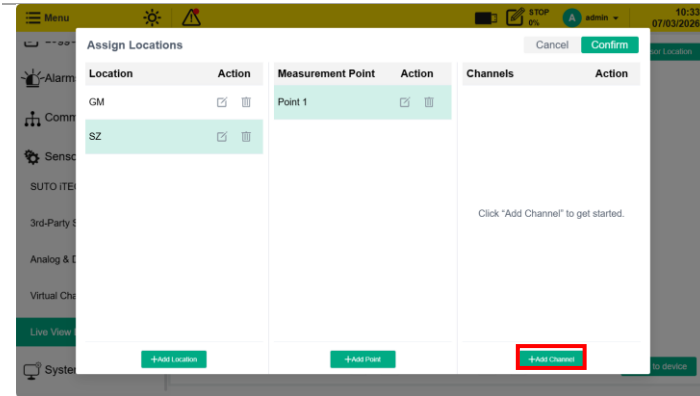

5. Click **+Add channel** button to assign the channel to each measurement point.

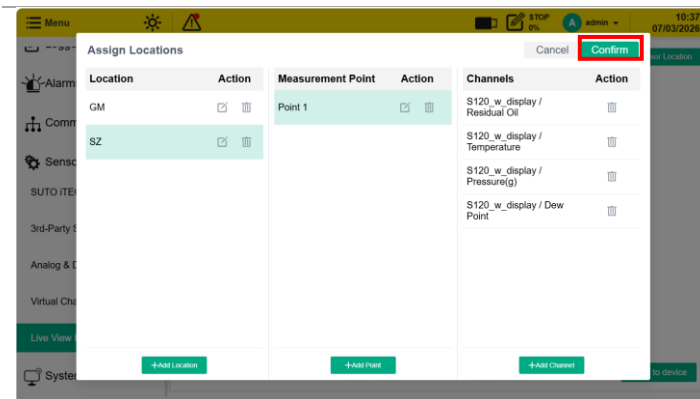

6. Click **Confirm**.

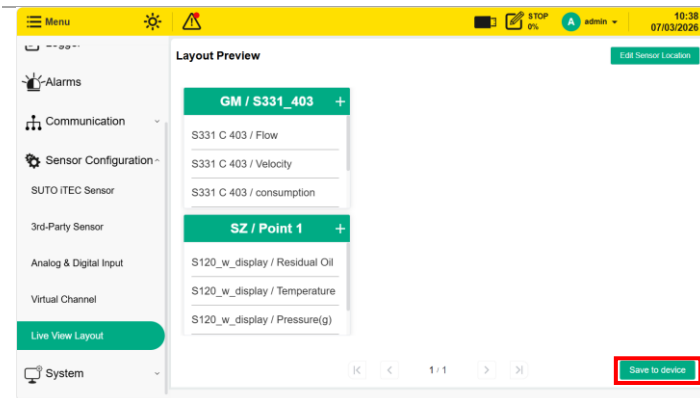

7. Each card is automatically arranged by the system. You can click the expand button on the card to expand it, and drag the card to adjust the layout manually. Please drag the card from right to left.

Click **Save to device** to commit the settings and layout.

Note:

All channels that belong to the same measurement point will be displayed in a single small card.

Attention: The channel's data will be displayed on the Home page **only after** you assign its location and measurement point.

9.4 Home

After the sensor configuration is completed, you can view the data of each channel on the Home page. Channels under the same measurement point will be displayed in a single card.

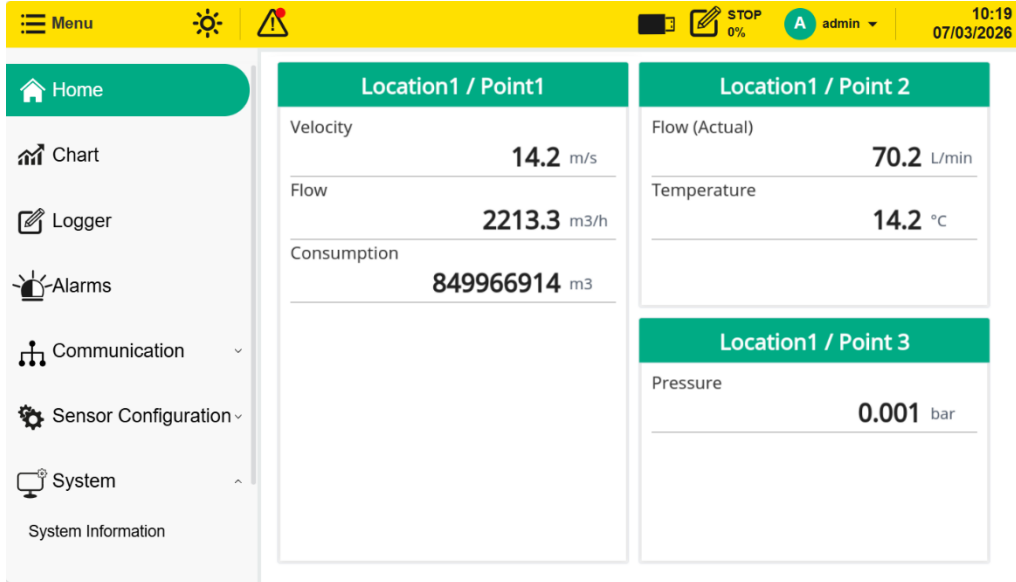

A maximum of 4 cards per page can be shown on the S332 display. Excess cards are automatically distributed across additional pages. Swipe left / right to navigate between pages.

The status bar is located at the top of the Home page. It displays icons for various functional statuses, as well as the account and system time etc.

	Click the "Menu" text or icon in the status bar to collapse or expand the menu bar.
	Click the Brightness icon to adjust the screen brightness.
	System error
	Alarm triggered. Click icon to enter the activated alarm page
	USB stick connected.
	Logger status. LOG: The logger is in the process of recording. STOP: The logger is stopped.
	The currently logged-in account name and account type.
	Date and time. Click the icon can go to time setting screen.
	Click the screenshot button to take a screenshot of the current screen.

9.5 Chart

The Chart page is empty when accessed for the first time.

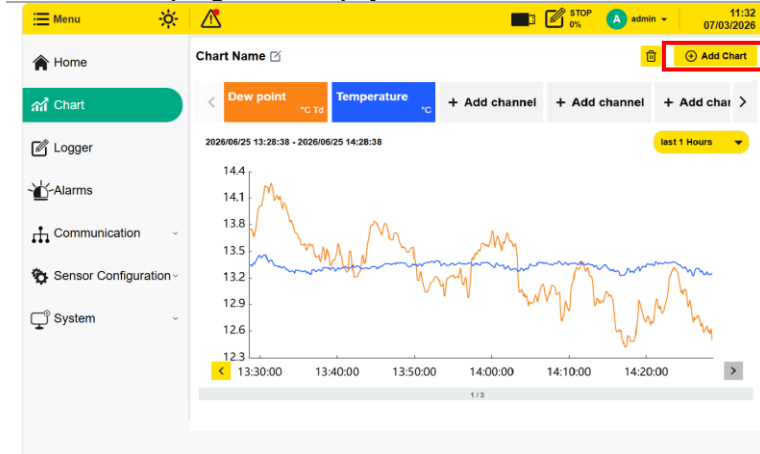

1. Long press the **+ Add Channel** area to enter the Channel Configuration page.

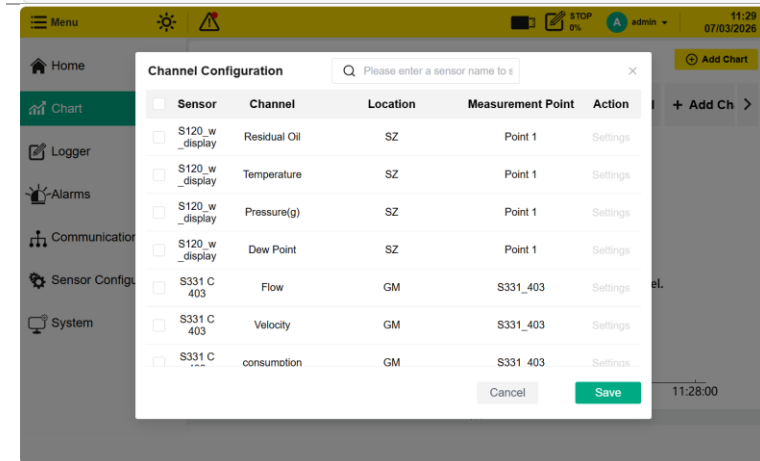

2. Select the specific channels you want to display on the Chart.

Click on the **Settings** button to configure the colour of the channel and set the Y - axis.

Note: Click on the **Settings** button can change the colour of the channel.

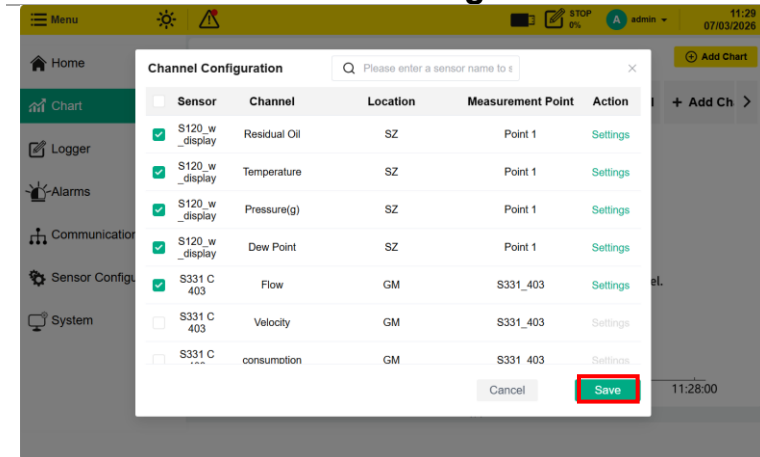

3. Click Save to save all the configuration.

Note: Curve recording initiates automatically once channel configuration is successful. Re-enter the Chart page to view the recorded curves.

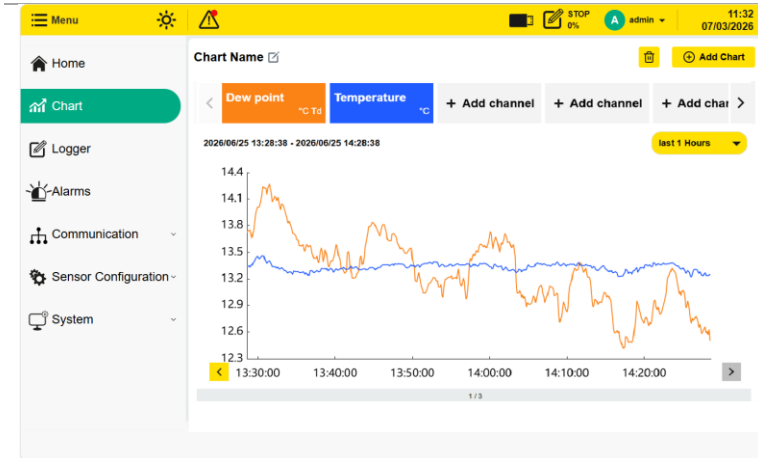

4. View the curves.
Swipe up or down to switch between different charts.

Click, double-click or long-press the channel areas to perform different operations:

- 1) Click: Display the Y-axis of the corresponding channel. The Y-axis of the leftmost channel is displayed by default.
- 2) Double-click: Temporarily hide the curve of the target channel. Double tap the same area again to restore the curve display.
- 3) Long-press: Re-enter the Channel Configuration page for re-editing the channel.

	Click this button to create additional chart (max. 4 charts supported in the Chart menu).
	Click this icon to edit the sensor information.
	Click this icon to remove sensor from the device.

9.6 Logger

9.6.1 Logger Core Functions

- Active logger information: Start or Stop the data recording.
- Log Files:
 - 1) Export log files;
 - 2) Table view for the raw data;
 - 3) Graphic view for the data analysis.

9.6.2 Active logger Information

Click **+Create Logger** to start and configure logging parameters.

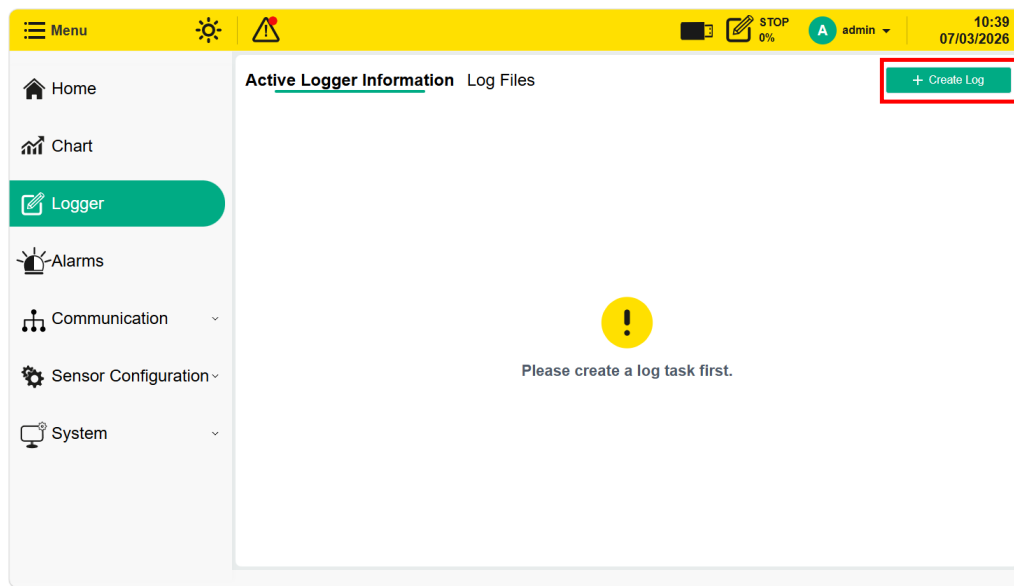

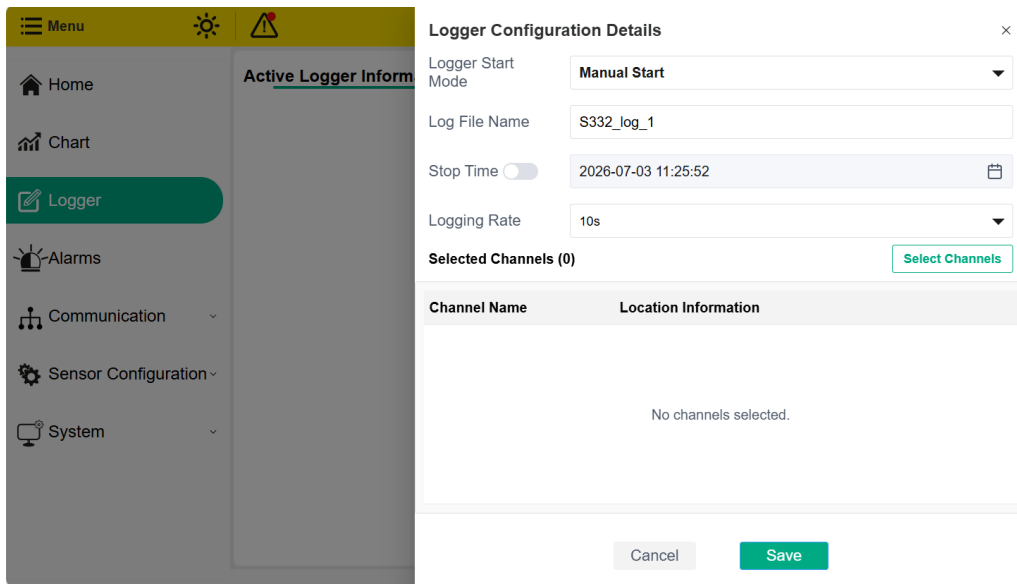

Startup Mode:

- Time Start: Set a specific start time for logging (scheduled recording).
- Key Start: Start immediately (logging begins right after configuration).
- Recorded file name: Enter a custom name for the generated log file.
- Stop time: Set a specific end time (logging stops automatically at the set time).

Additional Settings:

- Logger rate: Configure logging interval (time interval between consecutive data points).
- Select channels: Select channels to record (specify which data channels need to be logged).

A Stop button will appear after logging starts, click it to manually end recording. Stopping the logging will automatically save the log file for further use.

9.6.3 Log Files

The log files page displays all generated log files. The S332 allows multiple operations in this menu, like reviewing the logger data as graphic or table view, exporting and deleting single or multiple.

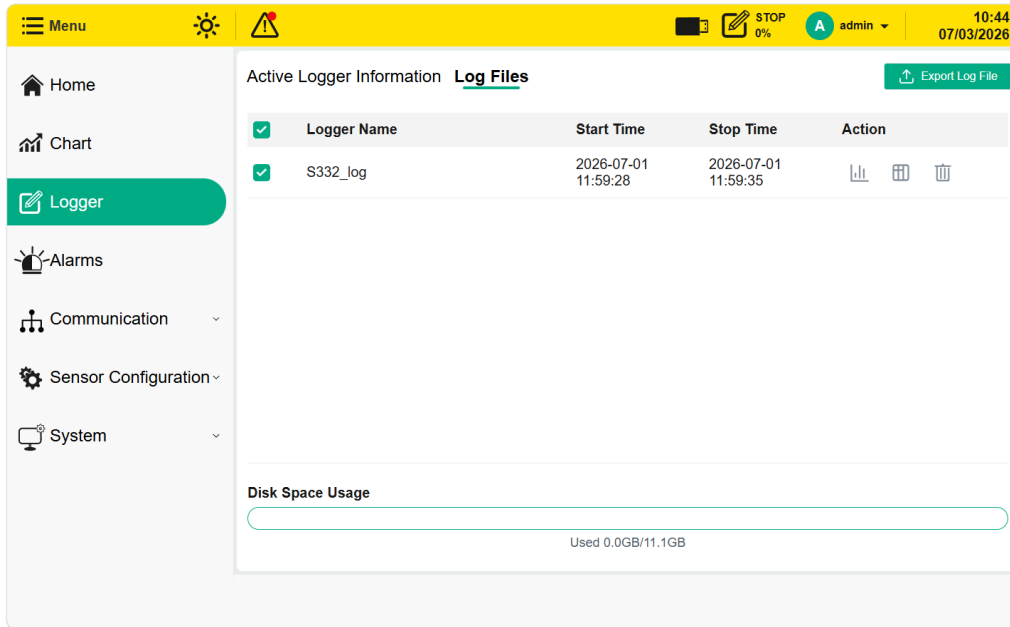

- Click this button to enter the graphic view (data displayed as curves).
- Click this button to enter the table view. (Raw data)
- Click this button to remove the recorded file
- Export Log File
Click this button to export the recorded files.

9.6.4 Export the Log Files

You can export the recorded file on S332 to a connected USB drive or via the S4C Web interface directly to the PC.

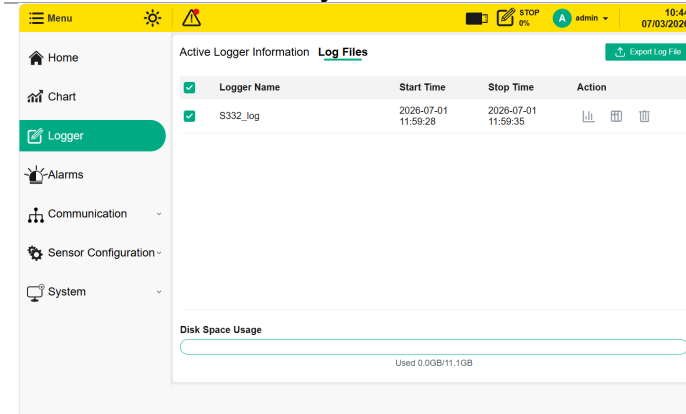

1. Insert a USB drive into the USB port on the front panel of the S332(for S332 local file export).
2. Go to the **Log Files** page.

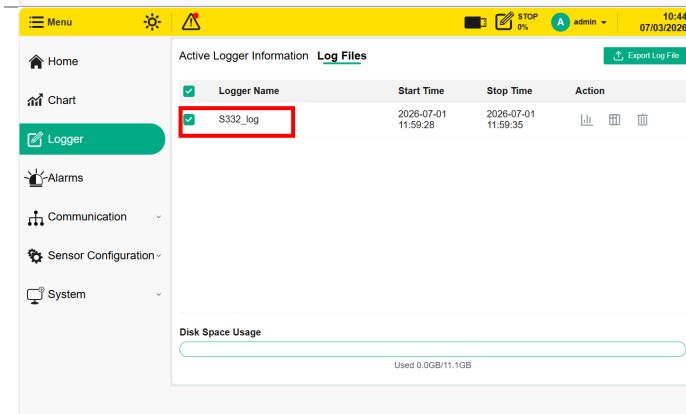

3. Select the files you want to export by checking the boxes next to them.

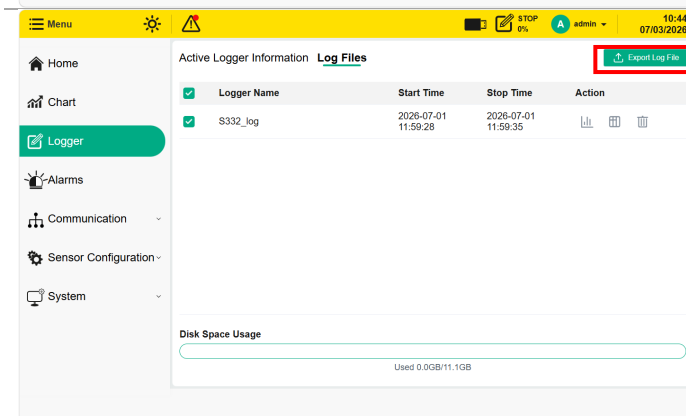

4. Click **Export Log File**.

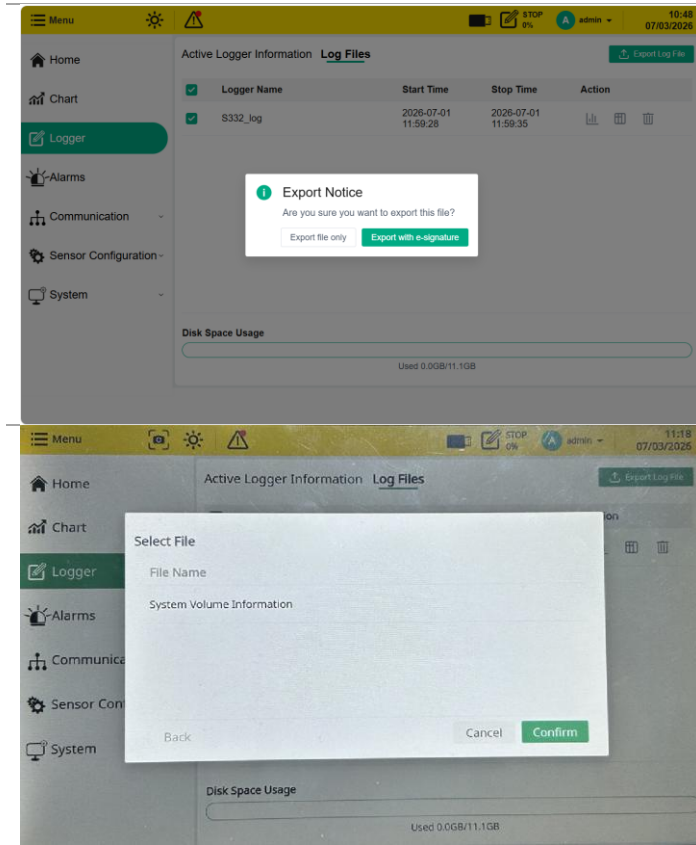

5. A pop-up window will appear to confirm whether you just want to export the file only or if you also need to attach an electronic signature.

6. A pop-up window will appear for you to choose the export path. (Only for local export on S332; For Web export path, please refer to your browser download settings).

7. After selecting the path, click **Confirm** to export the file to the USB drive or computer.

Note: If a signature is appended to the log file, two files will be generated per single record upon export. One is the csv data record file, and the other is the txt verification file for signature validation.

For example:

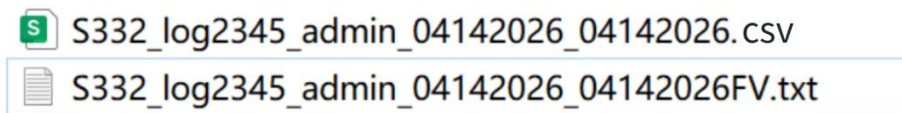

To complete signature verification, both files must be imported simultaneously. Refer to section 9.11 for detailed signature verification instructions.

9.7 Alarms

Alarms page is divided into three core sections:

- Alarm Settings: alarm configuration;
- Activity Alarms: real-time monitoring;
- Alarm History: historical data management.

9.7.1 Alarm Settings

Click **Create Alarm**, then select the channel to create an alarm setting.

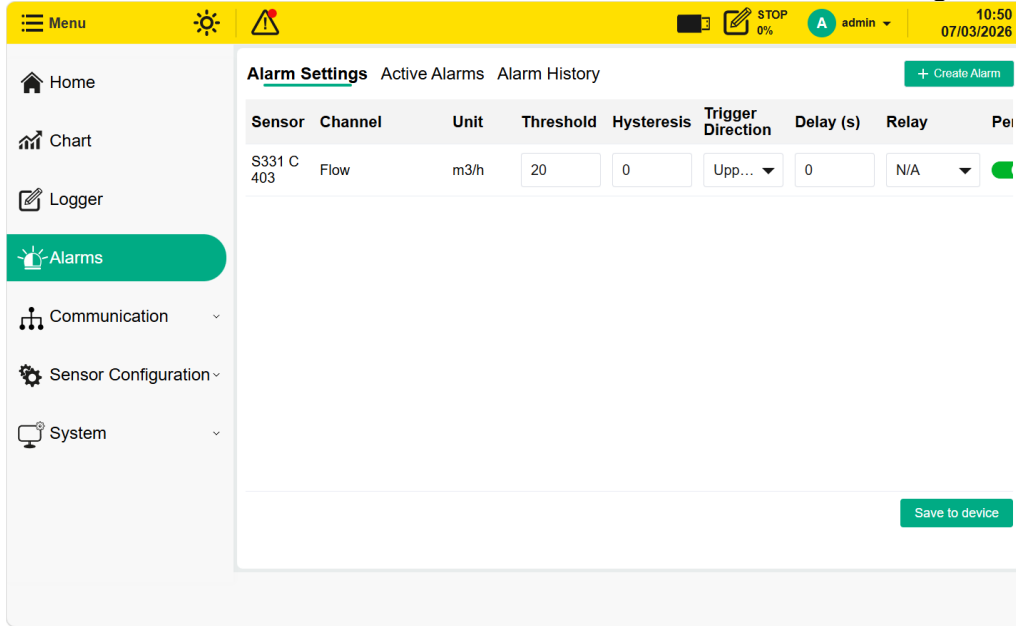

Unit	The unit is shown automatically after the channel is selected.
Threshold	Set a threshold
Hysteresis	The alarm is activated when the channel reading reaches the threshold and deactivated when the reading is the threshold minus hysteresis (high alarm) or the threshold plus hysteresis (low alarm). For example: The threshold is 30 and hysteresis is 5. High alarm is activated on channel reading ≥ 30 and deactivated on readings < 25 . Low alarm is activated on channel reading ≤ 30 and deactivated on readings > 35 .
Direction	UP indicates a high alarm. The alarm is activated when the reading is higher than the threshold. Down indicates a low alarm. It can avoid false alarms from transient fluctuations
Delay	Set the delay time for the alarm.
Relay	Select a relay. Relay 1 and Relay 2 are equipped by default.

In addition, the optional relay module offers 4 additional relays (Relay X9 to Relay X12). These 4 relays can be displayed and used only when the optional relay module is installed.

Pending When Pending selection box is chosen, the relay will not activate even an alarm is raised. This is typically used for maintenance and calibration to prevent false alarms.

9.7.2 Activated Alarms

Activated alarms page displays all currently active alarms in real time, including key information such as alarm channel, threshold, and relay, acknowledge status.

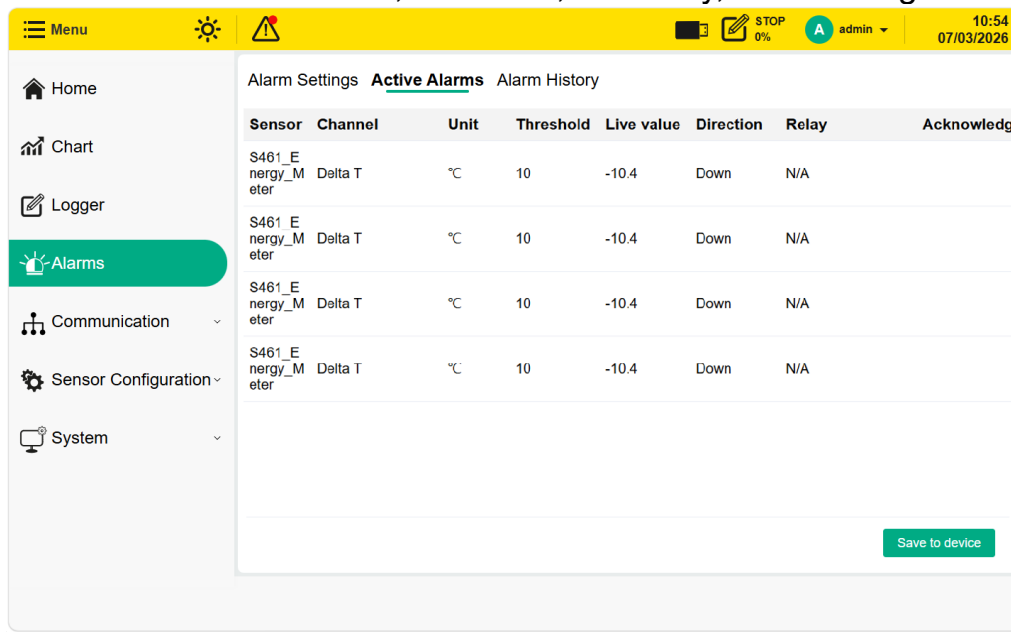

There are two ways to acknowledge alarms:

1. Permanent Reset
2. Timed Reset

Permanent Reset	To acknowledge the alarm immediately, and the relay will reset.
Timed Reset	To set a re-trigger time while acknowledging the alarm. When the set time is reached, the relay will re-trigger if the alarm still exists.

9.7.3 Alarm History

The alarm history page records all historical alarm records, including detailed information such as: alarm trigger time, alarm clear time (when the alarm condition is resolved), user who acknowledged the alarm etc.

Alarm time	Clear time	Status	Sensor	Channel	Unit	Trigger value	Threshold	Direction	Acknow Time/by
05-28-2026 11:39	-	Active	S461_Energy_Meter	Delta T	°C	-9.1	10	Down	
05-28-2026 11:38	-	Active	S461_Energy_Meter	Delta T	°C	-9.09	10	Down	
05-28-2026 11:38	-	Active	S461_Energy_Meter	Delta T	°C	-9.09	10	Down	
05-28-2026 10:36	-	Active	S461_Energy_Meter	Delta T	°C	-9.19	10	Down	



Click this button to filter information by channel, location, and time, allowing you to quickly find the alerts you need.



Click this button to export the historical alarm files.

9.8 Communication

The Communication menu provides the following functions:

- Ethernet settings;
- Modbus RTU master settings;
- Modbus RTU slave settings;
- Export holding register.

9.8.1 Ethernet Setting

Click **Communication > Ethernet Setting** to enter the page.

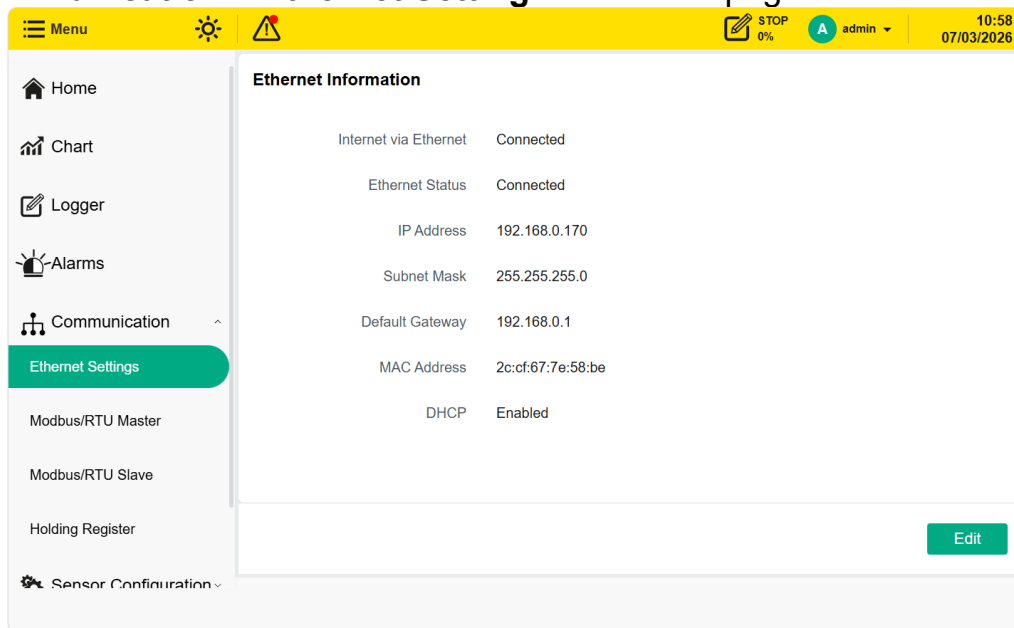

On the Ethernet information page, click **Modify**, then you can modify relevant IP settings.

Notes:

When DHCP is enabled, IP settings of the S332 are assigned automatically and cannot be configured manually.

9.8.2 Modbus/RTU Master

The Modbus/RTU master port is the input for the sensor via Modbus/RTU (RS-485). Click **Communication > Modbus/RTU Master** to enter the page.

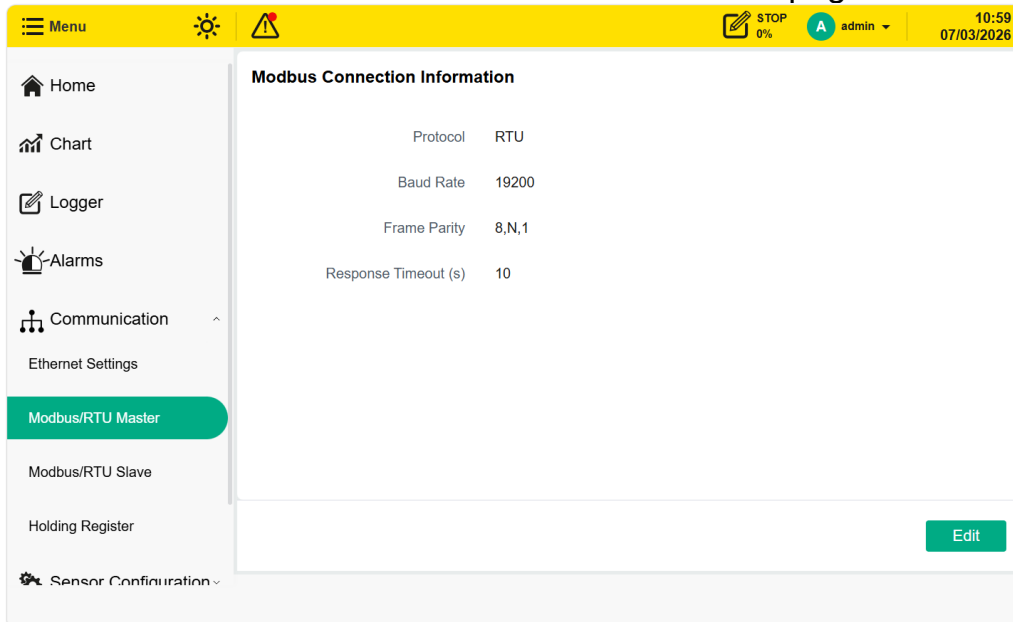

Click **Modify** to set related parameters.

Note:

For all sensors connected via the Modbus/RTU protocol, the communication parameters of the sensor must match exactly those of the S332 device, including baud rate and parity settings.

Mismatched parameters will cause communication failures.

9.8.3 Modbus/RTU Slave

The Modbus/RTU slave port is to connect S332 to a higher-level system /software via Modbus/RTU(RS-485).

Click **Communication > Modbus/RTU Slave** to enter the page.

Fieldbus RS-485 Connection Information

Protocol	RTU
Modbus Address	3
Baud Rate	38400
Frame Parity	8,E,1

[Edit](#)

Click **Modify** to set related parameters.

9.8.4 Holding Register Table

You can find the slave holding register under **Holding Register**.

Click **Export file** to export the S332 Holding register table. This holding register table is valid for both, the Modbus/RTU output as well as the Modbus/TCP output.

S332 Holding Register Table

Use this holding register table to read data from the S332 via Modbus/RTU or Modbus/TCP. [Export File](#)

Communication: RS485	Protocol: Modbus	Slave Address: 3
Baud Rate: 38400	Frame Spacing (Char): 7	Frame Spacing (µs): 2005
Response Delay (s): 5	Response Timeout (s): 10	Return Error Value: -9999

Measurement Point	Sensor	Channel	Address	Data Type	Byte Count	Unit	Resolution	Function Code
SZ/Point 1	S120_w_display	Residual Oil	0	FLOAT_L	4	mg/m3	0.001	3
SZ/Point 1	S120_w_display	Temperature	2	FLOAT_L	4	°C	0.1	3
SZ/Point 1	S120_w_display	Pressure(g)	4	FLOAT_L	4	bar(g)	0.1	3
SZ/Point 1	S120_w_display	Dew Point	6	FLOAT_L	4	°Ctd	0.1	3
GM/S331_403	S331 C 403	Flow	8	FLOAT_L	4	m3/h	0.1	3
GM/S331_403	S331 C 403	Velocity	10	FLOAT_L	4	m/s	0.1	3

9.9 System

9.9.1 Information & Update

System Information contains three sections:

- Basic Information
- Firmware update
- Configuration file

Basic Information

You can view basic information of the S332, such as serial number, firmware version, and hardware version.

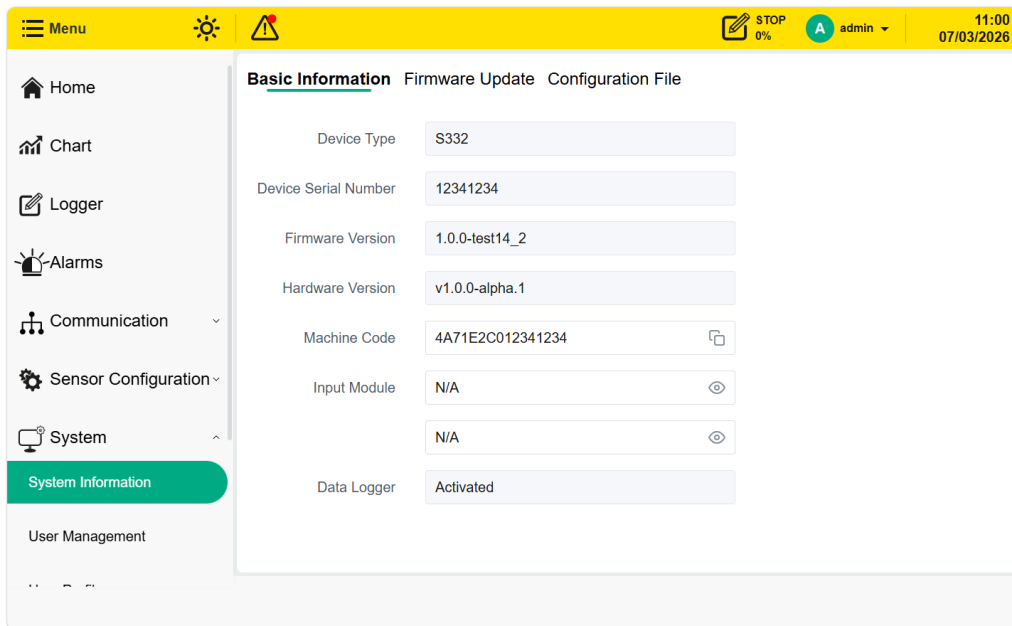

The Data Logger is an option for the S332. If an S332 was ordered without the logger option, it is possible to activate the logger remotely and retrospectively. Follow the below guidance.

To activate the Logger function:

- Contact SUTO iTEC sales team to purchase the Logger service.
- Provide the machine code to SUTO iTEC.
- SUTO iTEC will generate an activation code for you.
- Click **Activated** and enter the activation code to enable the logger function.

Firmware Update

Upgrade the firmware version of the S332 by selecting the firmware file.
For detailed operating procedures, see Section 9.11.

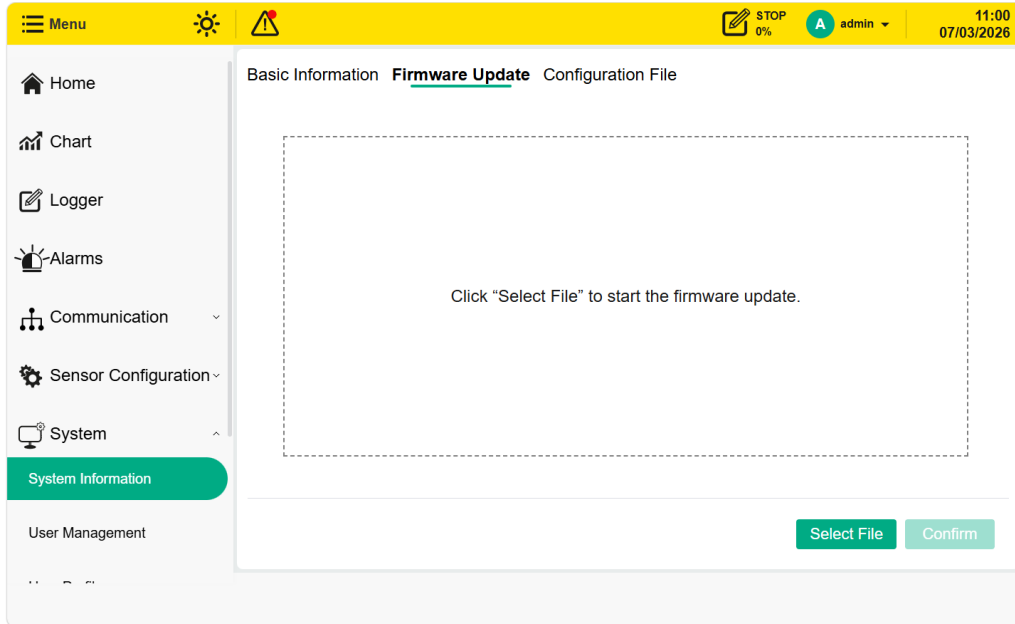

Configuration File

In the Configuration file submenu, you can generate and export a configuration file with the current settings of the S332 device. The exported configuration file can be applied to other identical S332 devices for rapid batch configuration.

It also supports importing an existing configuration file. All saved parameters will be loaded and applied directly to the S332 device, which simplifies configuration operations and improves on-site deployment efficiency.

By clicking **Generate file** to create the current configuration of the S332 as a configuration file.

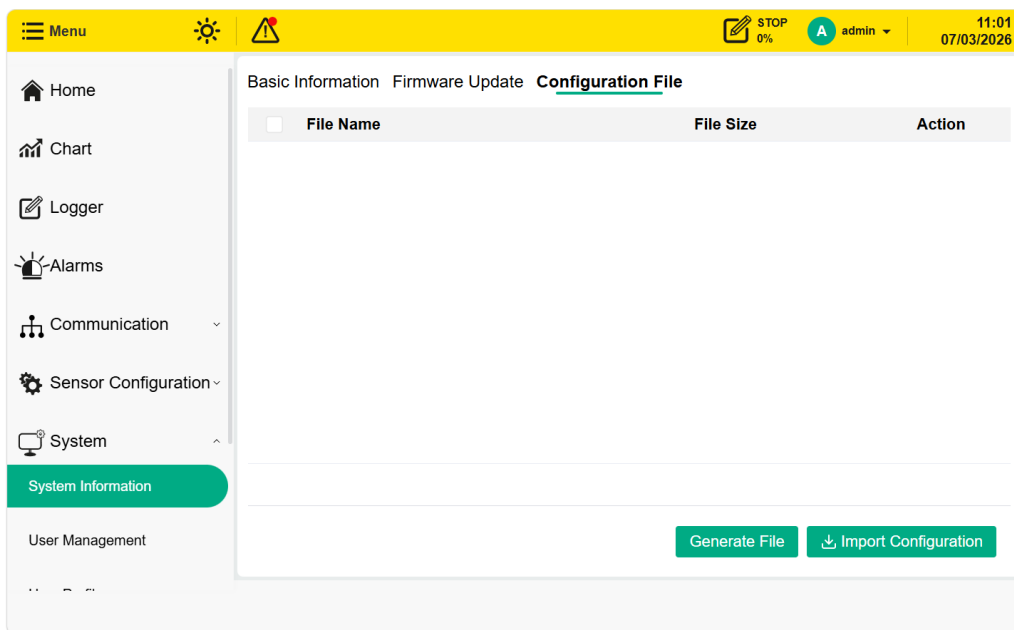

- ↑
Click this button to export the configuration file.
- 🗑️
Click this button to delete the configuration file.
- Generate File
Click this button to generate the latest configuration file.
- ↓ Import Configuration
Click this button to import the configuration file.

9.9.2 User Management

The User Management submenu is only available for the admin account. This page displays all available user accounts of the S332 device.

Follow steps below to add a new account.

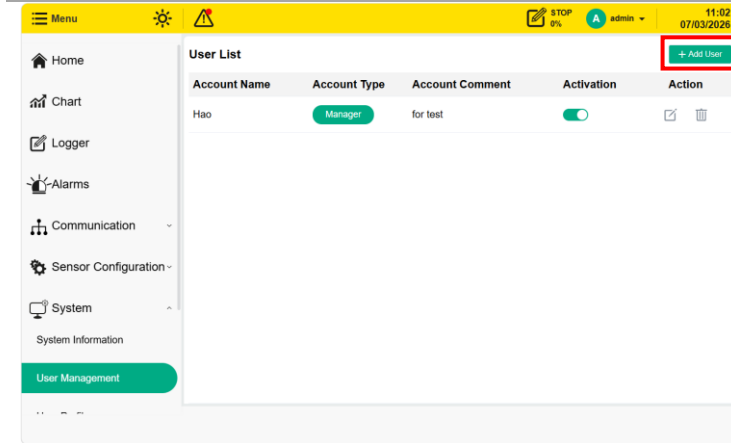

1. Click the **+Add user** button in the upper right corner.

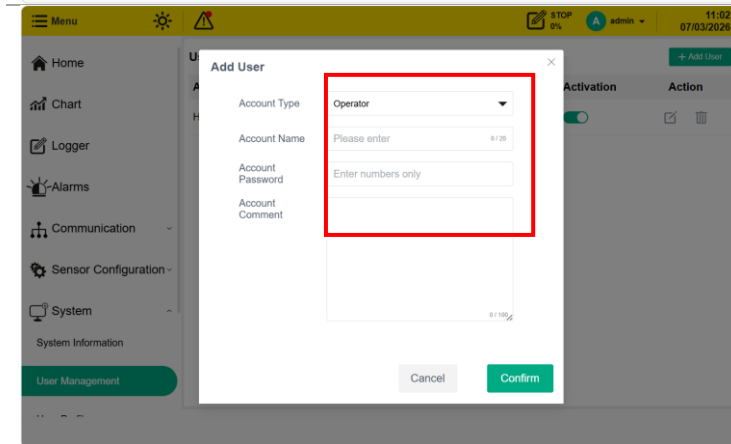

2. The Add User pop-up window appears, select the account type, set the user name, password and etc.

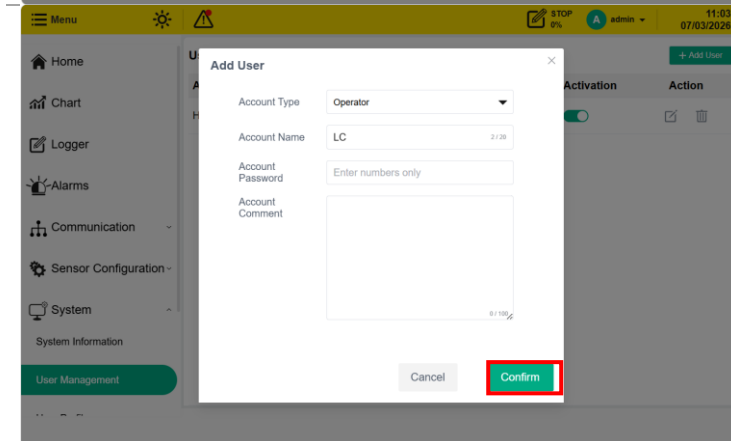

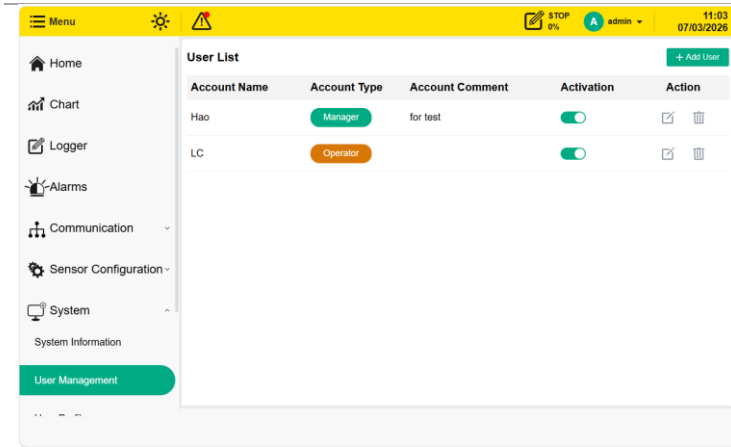

3. Click **Confirm**.



4. The newly created account will appear in the User Management list.

-  Click this icon to modify the account information

-  Click this icon to remove the account information

- Activation**
 Use the activation toggle switch to enable or disable the user account.

The S332 supports four account types: Operator, Manager, Auditor, and Admin. Different accounts have different permission levels. For detailed permissions, please refer to Appendix 3.

Note:

Only the Admin account is available on the S332 before shipment. The admin account can create other user accounts.

9.9.3 User Profile

You can view and edit your account information in the User Profile submenu.

Note: You cannot change the account type.

You can create electronic signature if needed.

- **Type Signature:** Generate a signature by manually entering text content.
- **None:** No electronic signature.

Note:

The image must be in PNG format and must not exceed 1 MB in size.

Once a file is attached with a signature, the file will be encrypted and cannot be modified.

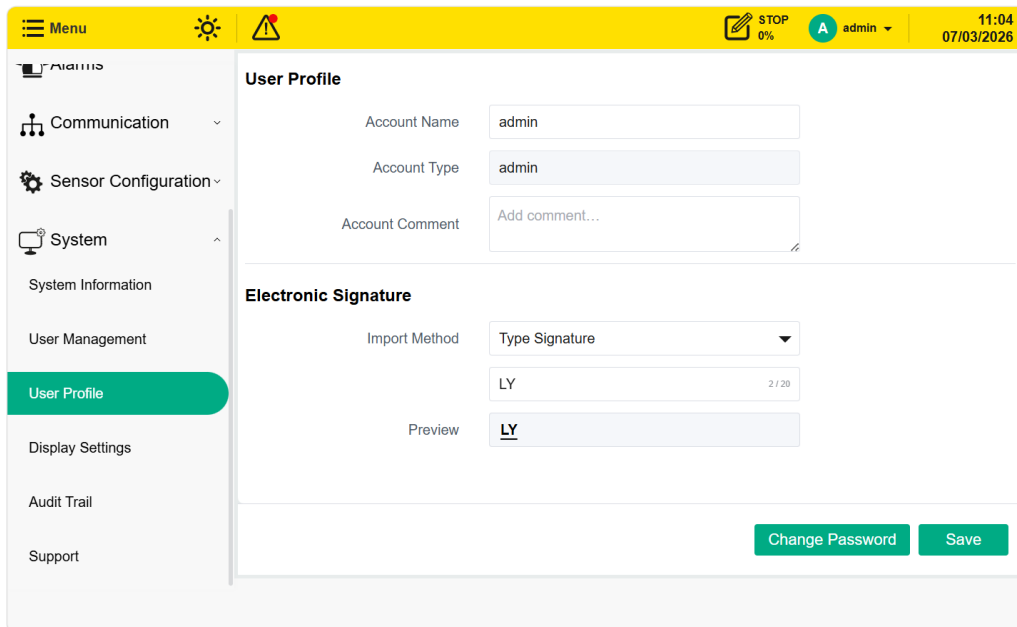

9.9.4 Display Settings

The Display Settings include three sections:

- Device lock
- Date and Time Setting
- Language

Device Lock

You can enable the auto screen lock function and set the auto lock period. When no operation is performed for the preset duration, the screen will enter the lock mode and go black without brightness.

You can wake up the screen by tapping the screen. After waking up the screen, login is required again. By checking 'stay log in' on the login page, you can avoid having to log in again on the wake-up page.

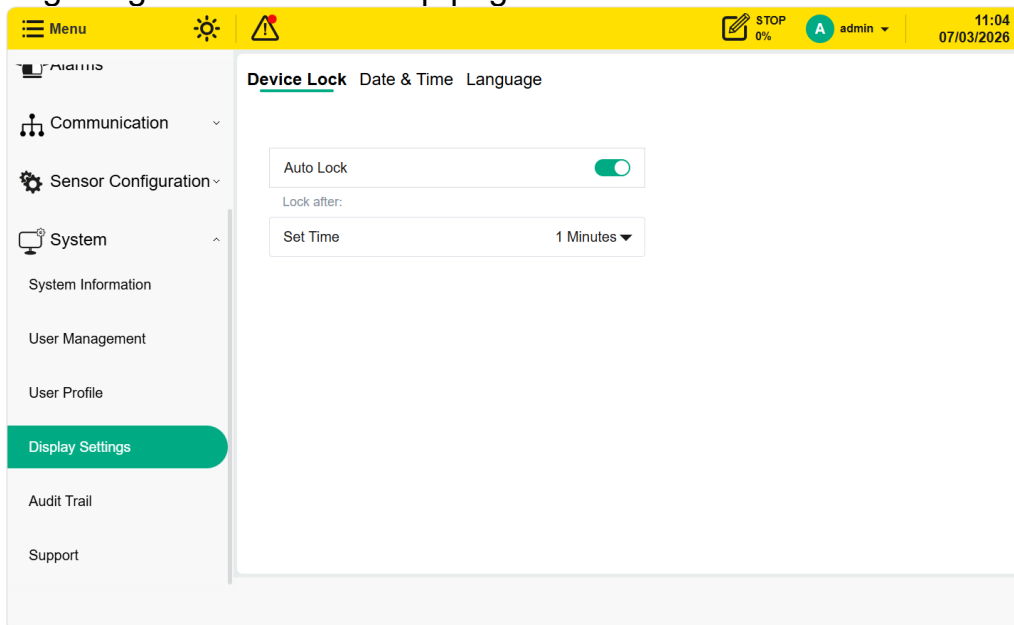

Date and Time Setting

The system time can be set manually or synchronized automatically with the PC time via the S4C display web.

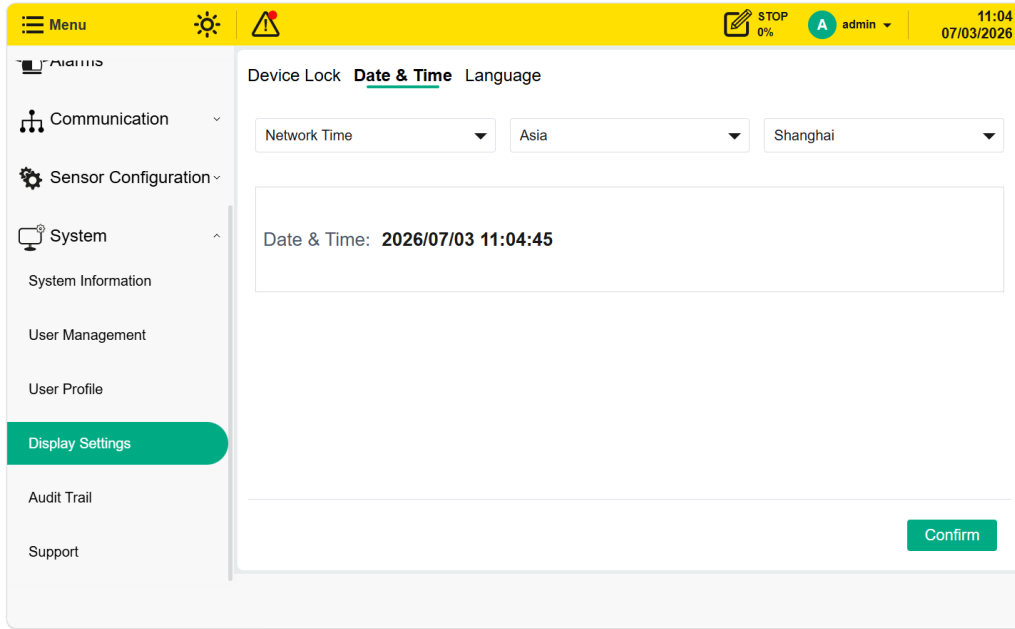

Language

Use this setting to select the language of the user interface.

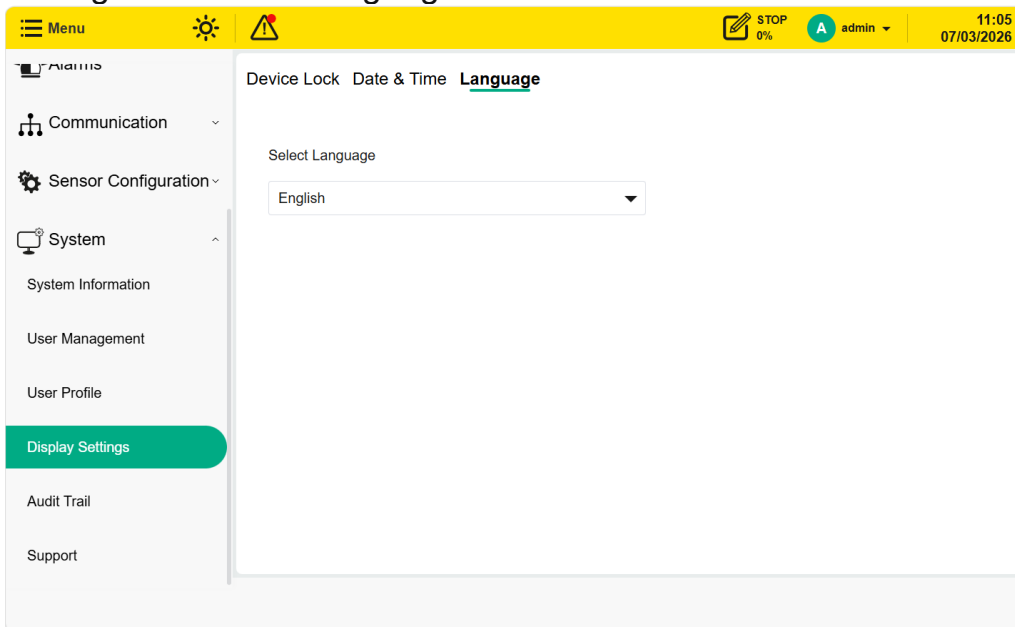



9.9.5 Audit Trail

The Audit Trail records all key operations performed on the system. It logs the time, the user account, and the operation details.

Note: Audit trail records will be signed and encrypted, and cannot be modified.

Item No.	Time	Username	Account Type	Operation Object	Operation Type	Before	After
354	2026-07-03 11:03:31	admin	Admin	Account	Create	None	"LC","created"
353	2026-07-03 10:53:32	admin	Admin	Layout setting	Update	Location: GM, Poin...	Location: GM, F
352	2026-07-03 10:52:46	admin	Admin	Sensor configuration	Create	None	Add Virtual Sen
351	2026-07-03 10:50:12	admin	Admin	Logger	Export	None	Export file: "S3
350	2026-07-03 10:48:23	admin	Admin	Account	Update	"admin","update si...	"admin","update
349	2026-07-03 10:48:23	admin	Admin	Account	Update	"admin","update u...	"admin","updat
348	2026-07-03 10:39:27	admin	Admin	Layout setting	Update	Location: SZ, Point...	Location: SZ, P

-  Click this button to view detailed operation information.
-  Click this button to filter audit trail records.
-  Click this button to export the audit trail records.

9.9.6 Support

The Support menu contains four submenus:

- Service Company Information
- Screenshot
- Device Overview

Service Company Information

You can configure service company information, such as company name, company address, and other related details. The data can be stored according to your needs and the operator of the S332 will find these details if support is needed.

The screenshot shows the 'Service Company Information' configuration page. The page has a yellow header with a 'Menu' icon, a sun icon, a warning icon, a 'STOP 0%' indicator, a user profile 'admin', and the time '11:05' and date '07/03/2026'. The left sidebar contains a menu with 'Support' highlighted in green. The main content area has three tabs: 'Service Company Information' (active), 'Screenshots', and 'Device Overview'. The form contains five input fields: 'Company Name' (as), 'Address' (da), 'Telephone' (da), 'Email' (wd.com), and 'Website' (afan.com). A green 'Save' button is located at the bottom right of the form.

Company Name	<input type="text" value="as"/>
Address	<input type="text" value="da"/>
Telephone	<input type="text" value="da"/>
Email	<input type="text" value="wd.com"/>
Website	<input type="text" value="afan.com"/>

Screenshot

You can view and export all screenshots.

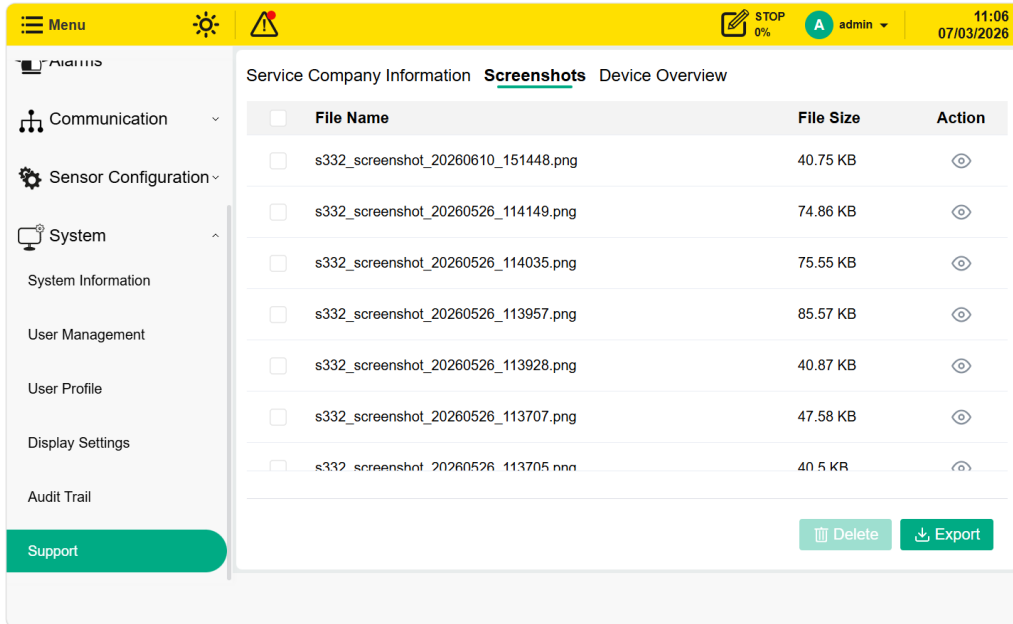

Click this icon to preview the screenshot.



Click this button to export the screenshot file to a connected USB drive.

Device Overview

The device information overview file stores all configuration parameters and settings of the S332. It supports export and can be used for equipment troubleshooting purposes.

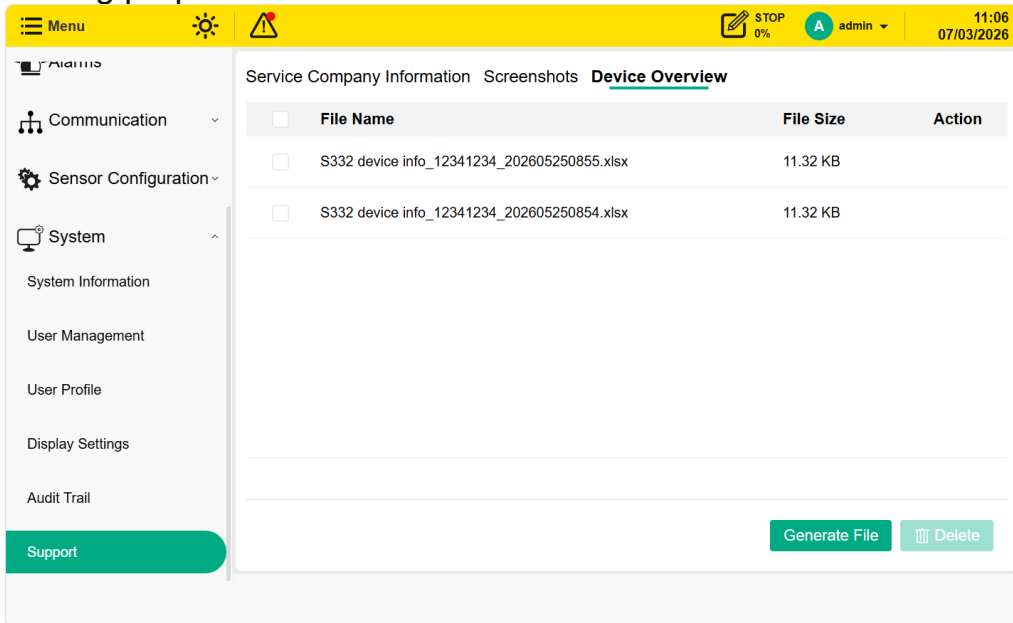

9.10 Firmware Update

System upgrade can be operated via either the S332 device or the S4C Web. Preparation required for the upgrade:

- The firmware file
- OTG-USB drive which supplied with the S332 (For S332 local upgrade only)

The following describes the upgrade procedure by taking operation on the S332 as an example.



1. Copy the firmware file into the USB drive then insert the USB drive to the connector on the front panel.

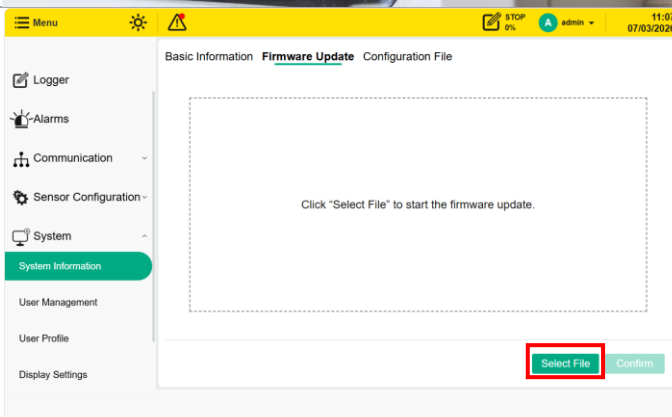

2. Enter the System information by clicking **System > Information & Update > Firmware update.** then Click **Select File** button.

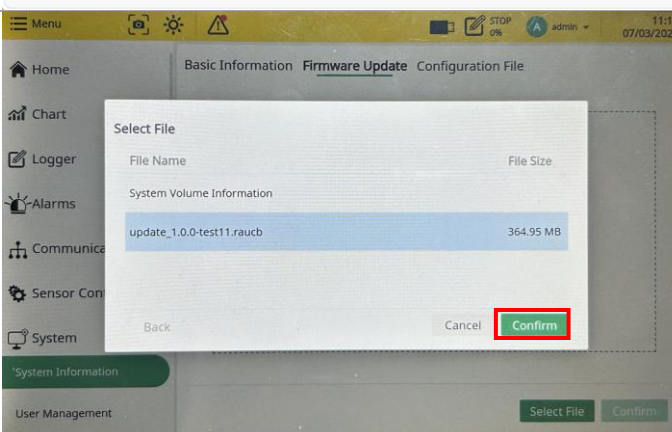

3. A pop-up window appears. Select the FW file, then Click **Confirm.**

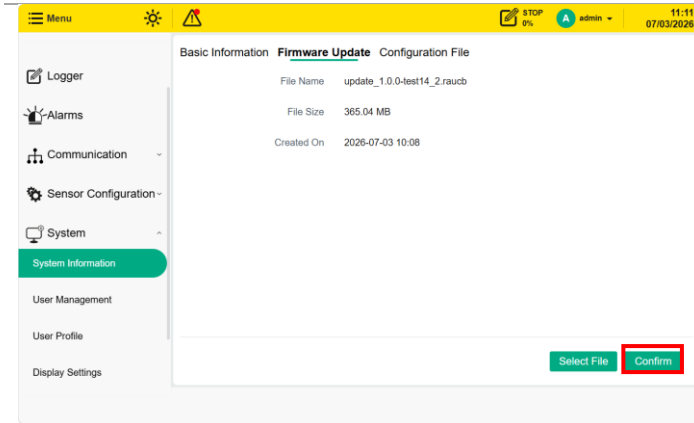

4. Click **Confirm**.

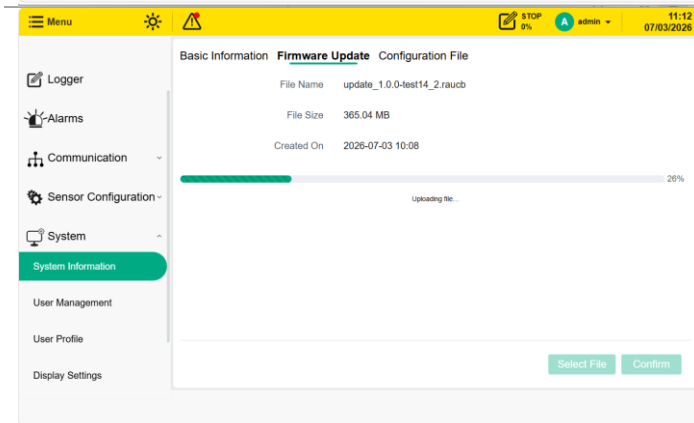

5. The system is starting to update. Once the upgrade is complete, the S332 will automatically restart.

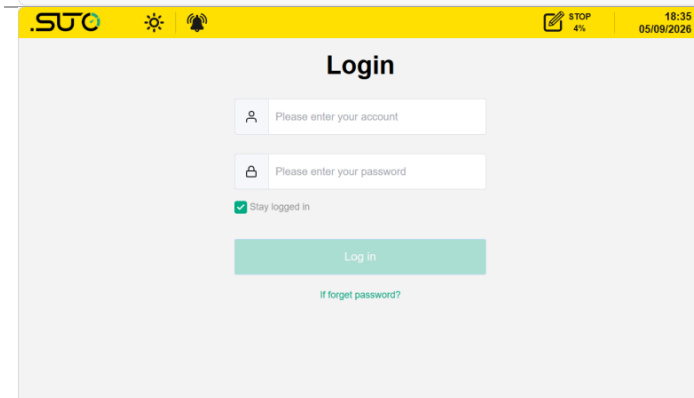

7. After restarting, the login page will appear. Once you log in, you can use the S332 as usual.

Upgrade via S4C Display Web Remote follows nearly the same steps as the S332.

1. Transfer the firmware file to your computer
2. Follow the steps above to perform the update
3. After the upgrade is completed, the S4C web will not show a restart process.
4. Wait one to two minutes, then log in again.

Please note during a firmware update:

- Make sure to do this after the S332 has fully booted.
- Make sure you do not turn off the power.
- Make sure you do not disconnect the USB drive (S332 local upgrade).
- Wait until the device is fully booted again before removing the USB drive (S332 local upgrade).
- Make sure that the LAN connection and communication between the computer

and the S332 are functioning properly during the upgrade.

9.11 S4C Web offline version

The S4C Web Offline Configuration Tool is intended for field installations where S332 cannot connect to a LAN. You may generate configuration files on a PC and download them to the S332, enabling straightforward and convenient device configuration.

It supports two core functions: offline configuration file generation and the file verification.

9.11.1 Configuration file

No local software installation on the PC is required. You can directly access the tool via the link below:

URL: <https://s4c.suto-portal.com/>

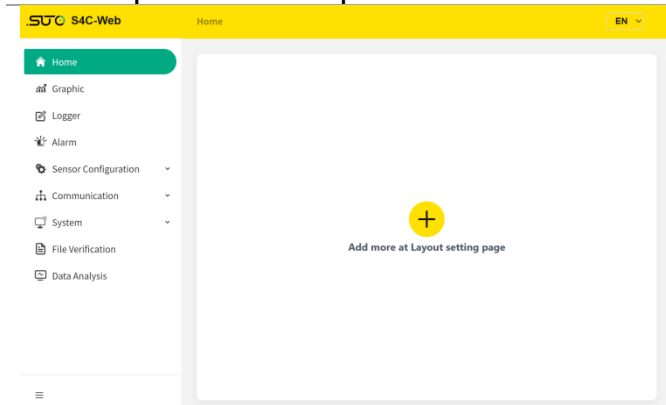

Open the specified link on a PC to enter the Web Offline configuration page directly.

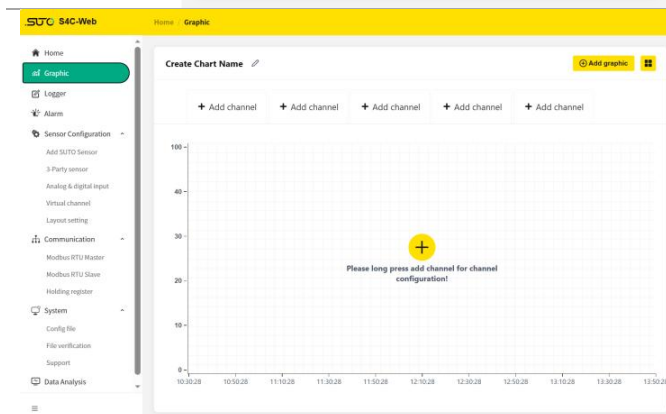

Set all required parameters item by item, including Chart, Logger, Alarm, Sensor Configuration, Communication and support settings. (The procedure is similar to that in sections 9.3 - 9.9)

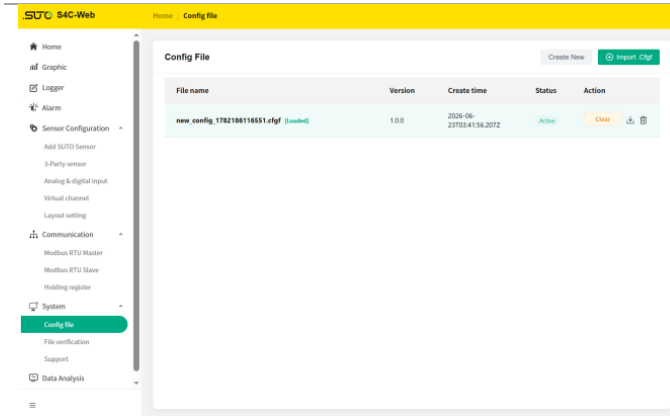

After all configurations are completed, Click  icon to export the configuration file.

Then you can import the configuration file into the S332 to complete device configuration.

Note:

If you already have an existing S332 configuration file and need to revise it to create a new one, click the **Import. Cfgf** button to load the original file. Set its status to Active first, adjust relevant parameters as required, then export the updated file to finish modification.

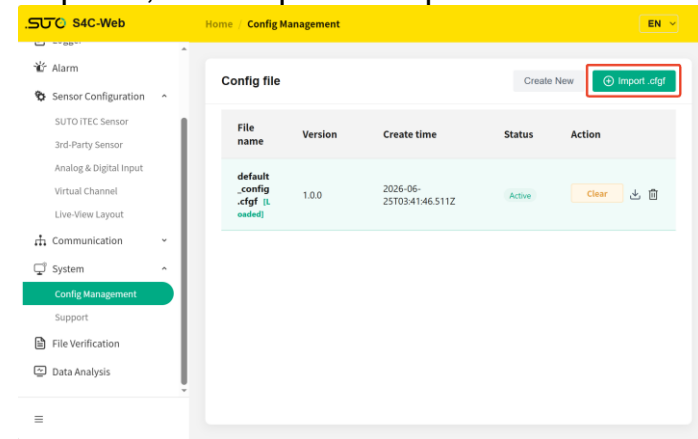

9.11.2 File verification

It supports file signature verification, to check whether the content of signed configuration files has been tampered with.

Enter the **File Verification** page, upload both the file with signature and corresponding verification file simultaneously. The system will execute automatic verification.

Result **Pass**: Valid signature, file content remains unchanged.

Result **Fail**: Invalid signature, file content has been modified.

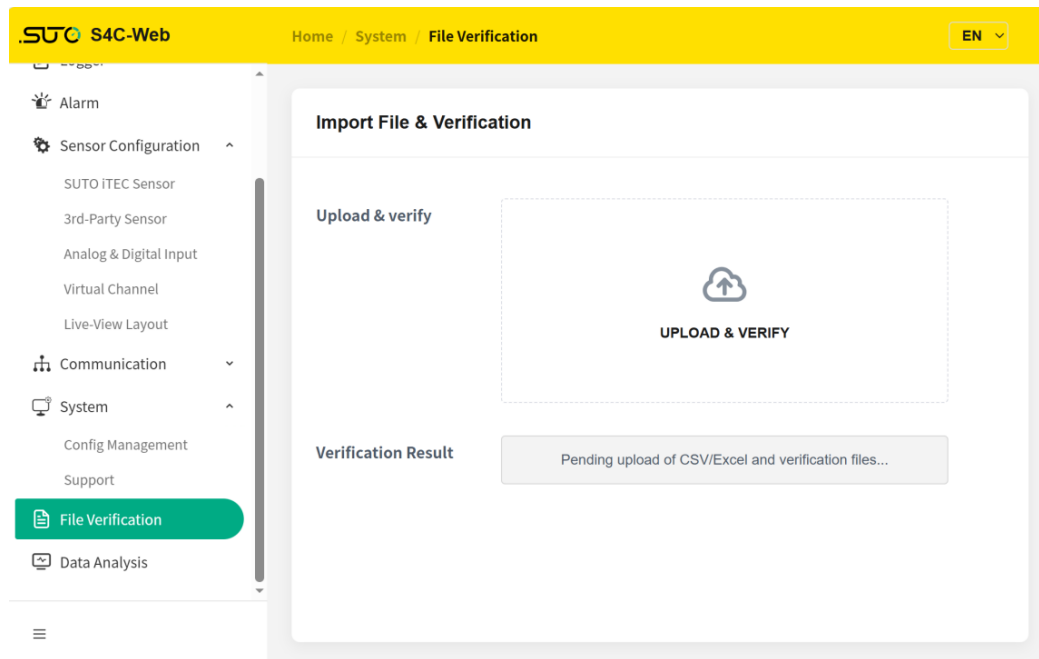

10 Optional Accessories

A3003	Analog Input Module, 4 Channels, Current: 0...20 mA / 4...20 mA
A3004	Analog Input Module, 4 Channels, Voltage: 0... 10 V / 0.5... 4.5 V
A3005	Digital Input Module, 4 Channels
A3006	Alarm Relay Module, 4 Relays, Rating: 3 A @230 VAC / 3A@30 VDC

A554 0136 WTU-S, Wireless Transmission Unit for stationary installation, Slave (default) / Repeater with 0.5 m M12 connection cable, M12 connector for power supply, all installation accessories included.

A554 0137 WTU-S, Wireless Transmission Unit for stationary installation, Master with 1 m open ends, M12 connector for power supply, all installation accessories included.

11 Maintenance

- Clean the display surface regularly to remove dust, oil, and moisture.
- Ensure the operating environment is free from excessive heat, humidity, vibration, or corrosive substances.
- Ensure the unit is securely mounted without vibration or looseness.
- Avoid exposure to direct sunlight, condensation, and chemical splashes.
- Maintain the temperature and humidity within the specified operating range.
- Check the grounding and EMC protection regularly.
- To clean the device, it is recommended to use a moist cloth only.



ATTENTION!

Do not use isopropyl alcohol to clean the display!

12 Disposal of Waste



Electronic devices are recyclable material and do not belong in the household waste.

The sensor, the accessories and its packings must be disposed according to your local statutory requirements. The dispose can also be carried by the manufacturer of the product, for this please contact the manufacturer.

1 Appendix A – Modbus Interface

The default settings of the Modbus interface are as follows:

Mode	:	TCP
DHCP	:	Yes
MAC	:	Set ex-factory
IP address	:	Dynamic or Static
Subnet	:	Dynamic or Static
Gateway	:	Dynamic or Static
Timeout	:	≥ 200 ms

Mode	:	RTU
Baud rate	:	19200
Device address	:	1
Framing / parity / stop bit	:	8, N, 1
Response time	:	1 second
Response delay	:	0 ms
Inter-frame spacing	:	7 char

Response message that the device returns to the master:

- Function code: 03

The information of the byte order is shown in the table below:

Byte Order	Sequence				Data Type
	1st	2nd	3rd	4th	
1-0-3-2	Byte 1 (MMMMMMMM*)	Byte 0 (MMMMMMMM*)	Byte 3 (SEEEEEEE)	Byte 2 (EMMMMMMM*)	FLOAT
1-0-3-2	Byte 1	Byte 0 LSB	Byte 3 MSB	Byte 2	UINT32 INT32
1-0	Byte 1 MSB	Byte 0 LSB	---	---	UINT16 INT16
1-0	Byte 1 XXX *	Byte 0 DATA	---	---	UINT8 INT8

* S: Sign, E: Exponent, M: Mantissa, XXX: no value

Explanations of MSB and LSB

MSB MSB refers to Most Significant Byte first, which follows the Big-Endian byte order.

For example, if the main system follows the MSB first order:

When the 4-byte floating number, in the order of Byte1-Byte0-Byte3-Byte2, is received from the slave (sensor), the master must change the byte order to Byte3-Byte2-Byte1-Byte0 for the correct display of the value.

LSB LSB refers to Least Significant Byte first, which follows the Little-Endian byte order.

For example, if the main system follows the LSB first order:

When the 4-byte floating number, in the order of Byte1-Byte0-Byte3-Byte2, is received from the slave (sensor), the master must change the byte order to Byte0-Byte1-Byte2-Byte3 for the correct display of the value.

2 Appendix B – Power Consumption of Sensors

The Compact and Flex S332 can provide a maximum 50 W and 150 W power supply separately to connected sensors. The following table shows the power consumption of the sensors supported by S332.

If the total power consumption of connected sensors is greater than 50 W (AC version) or 150 W (DC version), please use an external power source.

Device/Sensor	Power consumption [W]	
	Without display	With display
S401 / S421	4.8	5.8
S403/S423	1.3	2.1
S415/S418/S418V	N/A	2.9
S430	1.8	2.2
S450 / S452	4.5	4.8
S451 / S453	N/A	4.3 (Heater off) 5.0 (Heater on)
S211/S215/S220 (2-wire)	0.5	N/A
S211/S215/S220 (3-wire)	1.0	1.2
S211/S215/S220 (Modbus/RTU)	1.0	1.2
S211/S215/S220 (With pressure sensor)	1.0	1.2
S110	1.0	N/A
S120	5	10
S130/S132	5	10
Pressure Transmitter	0.5	N/A
Electrical Current Transmitter	0.8	N/A
S111/S111-UL	N/A	3.5
S040	0.015	N/A

3 Appendix C-Account and permission

R=Read only (User can view the content, but can not edit or export), R&O=read and operation, - mean have no permission to view

Menu	Descriptions	Operator	Manager	Auditor	Admin
Home	Show channel values	R	R	R	R
Chart	Show chart based on channels	R	R	R	R
	Configure the chart	R	R&O	R	R&O
Logger	Active Logger information	R	R&O	R	R&O
	Log files(export)	R&O	R&O	R&O	R&O
	Log files (delete, rename, change...)	R	R&O	R	R&O
Alarms	Alarm Settings	R	R&O	R	R&O
	Activated Alarms	R	R&O	R	R&O
	Alarm History	R&O	R&O	R	R&O
Communication	Ethernet Settings	R	R&O	R	R&O
	Modbus/RTU Master	R	R&O	R	R&O
	Modbus/RTU Slave	R	R&O	R	R&O
	Holding Register	R	R&O	R	R&O
Sensor Configuration	SUTO ITEC sensor	R	R&O	R	R&O
	3rd-party sensor	R	R&O	R	R&O
	Analog&Digital input	R	R&O	R	R&O
	Virtual Channel	R	R&O	R	R&O
	Live View Layout	R	R&O	R	R&O
System	System Information	R	R&O	R	R&O
	User Management	-	-	-	R&O
	User profile	R&O	R&O	R&O	R&O
	Display Settings: Device lock	R&O	R&O	R	R&O
	Display Settings: Language Time & Date	R	R&O	R	R&O
	Audit Trail	R&O	R&O	R&O	R&O

	Support	Service company info	R	R&O	R	R&O
		Screenshots	R&O	R&O	R	R&O
		Device overview	R&O	R&O	R	R&O

Contact Details

SUTO iTEC GmbH

Grißheimer Weg 21
D-79423 Heitersheim
Germany

Tel: +49 (0) 7634 50488-00
Email: sales@suto-itec.com

SUTO iTEC (ASIA) Co., Ltd.

Room 10, 6/F, Block B, Cambridge Plaza
188 San Wan Road, Sheung Shui, N.T.
Hong Kong

Tel: +852 2328 9782
Email: sales.asia@suto-itec.com

SUTO iTEC Inc.

5460 33rd St SE
Grand Rapids, MI 49512
USA

Tel: +1 (616) 800-7886
Email: sales.us@suto-itec.com

SUTO iTEC (China) Co. Ltd

11A Floor, D3 Building, TCL International E City
No. 1001 Zhongshanyuan Road
Nanshan District, Shenzhen 518057
China

Tel: 400-616-6126
Email: sales.cn@suto-itec.com

SUTO iTEC India

2062-2063, S-wing 2nd Floor,
Akshar Business Park, Plot No 3,
Sector 25, Vashi, Navi Mumbai – 400 703
India

Tel: +91-9825744804
Email: sales.in@suto-itec.com

SUTO iTEC (Thailand) Co., Ltd.

18/6 Romkiao Road, Khlong Sam Prawet, Lat
Krabang
Bangkok 10520
Thailand

Tel: +66 (0)2108 9658
Email: sales.th@suto-itec.com

PT SUTO iTEC Indonesia

ITC Cempaka Mas Office Tower 8th floor
room 8 B. Jl. Letjend Suprpto Kav 1
Jakarta 10640
Indonesia

Tel: +6221 4280 3853
Email: sales.id@suto-itec.com

SUTO iTEC (Malaysia) Sdn Bhd

No.22-A, Jalan Tiara 2
Tiara Square, UEP Subang Jaya Industrial Park
47600 Subang Jaya Selangor
Malaysia

Tel: +603 5122 2082
Email: sales.my@suto-itec.com
