

Operating Manual
PrimaX® IR+
Gas Detector



Order No.: 10246567/00

Print Spec: 1000005196 (EO)

CR:800000065206

⚠ WARNING!

These instructions must be provided to users before use of the product and retained for ready reference by the user. Read this manual carefully before using or maintaining the device. The device will perform as designed only if it is used and maintained in accordance with the manufacturer's instructions. Otherwise, it could fail to perform as designed, and persons who rely on this device could sustain serious injury or death.

The warranties made by MSA with respect to the product are voided if the product is not installed and used in accordance with the instructions in this manual. Please protect yourself and your employees by following the instructions.

Please read and observe the WARNINGS and CAUTIONS inside. For additional information relative to use or repair, call 1-800-MSA-2222 during regular working hours.

The Declaration of Conformity can be found under the following link: <https://MSAsafety.com/DoC>.

MSA is a registered trademark of MSA Technology, LLC in the US, Europe and other Countries. For all other trademarks visit <https://us.msasafety.com/Trademarks>.



The Safety Company

1000 Cranberry Woods Drive
Cranberry Township, PA 16066
USA
Phone 1-800-MSA-2222
Fax 1-800-967-0398

For your local MSA contacts, please go to our website www.MSAsafety.com

Contents

1	Safety Regulations	4
1.1	Correct Use	4
1.2	Liability Information	4
1.3	Safety and Precautionary Measures to be Adopted	5
1.4	MSA Permanent Instrument Warranty	5
2	Description	7
2.1	User Interface	7
2.2	Package Contents	8
3	Installation	10
3.1	Mechanical Installation	10
3.2	Electrical Installation	14
4	Remote Controller and Menu Sequence	17
4.1	Remote Controller (sold separately)	17
4.2	Menu Item	17
5	Start-up and Calibration	21
5.1	Remote Controller and Menu Sequence	21
5.1.1	Initial Start-up	21
5.2	PrimaX IR+ Calibration	23
5.3	Calibration Kits	31
6	Maintenance	32
6.1	General	32
6.2	Troubleshooting	32
6.3	HART Information for Troubleshooting	33
6.4	Cleaning	33
6.5	Calibration Cap Cleaning Procedure	35
7	Technical Data	36
8	Ordering Information	37
8.1	Spare Parts	37
8.2	Accessories	37
8.3	Flowcap	38
8.4	Sunshield	38
8.5	Duct Mount Flange	38
8.6	HART Module	39
8.7	Insect Guard Remote Calibration Inserts	40
9	General Certification Information	41

1 Safety Regulations

1.1 Correct Use

The PrimaX® IR+ - referred to hereafter as device - is a fixed infrared combustible gas detector. It is suitable for outdoor and indoor applications, e.g. offshore industry, chemical and petrochemical industry, water and sewage industry.

The device utilizes infrared technology to monitor, detect and alert users to potentially dangerous levels of combustible hydrocarbon gas. Dual source technology offers 100% redundancy on the optical source to maximize reliability and lifetime. This device allows for extremely fast response time whilst providing an extremely stable output signal.

The device is a stand-alone unit with a 4 to 20 mA output with HART (Highway -Addressable Remote Transducer) digital information encoded on the analog output. The signal of the transmitter can be used in combination with MSA control units for further actions in safety or non-safety applications. Contact your MSA representative for available controllers.

The device is shipped factory-calibrated and is labeled with target gas, calibration gas and span setting information for ease of use. Any user changes to the factory assigned values should be noted on the device labels.

The device is explosion-proof and suitable for installation in hazardous locations. It can be used as a stand-alone unit or integrated with a control system to alert operators to the presence of combustible hydrocarbon gas.

It is imperative that this operating manual be read and observed when using the product. In particular, the safety instructions, as well as the information for the use and operation of the product, must be carefully read and observed. Furthermore, the national regulations applicable in the user's country must be taken into account for a safe use.

WARNING!

- Read this manual carefully. The device will perform as designed only if it is used, installed, and maintained in accordance with the manufacturer's instructions. Otherwise, it could fail to perform as designed and persons who rely on this device for their safety could sustain serious personal injury or loss of life.
- This product is supporting life and health. Inappropriate use, maintenance or servicing may affect the function of the device and thereby seriously compromise the user's life.
- Before use the product operability must be verified. The product must not be used if the unit fails to power on, it is damaged, a competent servicing/maintenance has not been made, genuine MSA spare parts have not been used.
- For safety reasons this equipment must be operated and serviced by qualified personnel only.

Failure to follow these warnings can result in serious personal injury or death.

Alternative use, or use outside this specification will be considered as non-compliance. This also applies especially to unauthorized alterations to the product and to commissioning work that has not been carried out by MSA or authorized persons.

1.2 Liability Information

MSA accepts no liability in cases where the product has been used inappropriately or not as intended. The selection and use of the product are the exclusive responsibility of the individual operator.

Product liability claims, warranties also as guarantees made by MSA with respect to the product are voided, if it is not used, serviced or maintained in accordance with the instructions in this manual.

1.3 Safety and Precautionary Measures to be Adopted

WARNING!

- The device described in this manual must be installed, operated and maintained in strict accordance with the labels, warnings, cautions, instructions, and within the limitations stated.
- Protect the device from extreme vibration.
- Do not mount the device in direct sunlight without a sunshield, since this may cause it to overheat.
- The only absolute method to ensure proper overall operation of the device is to check it with a known concentration of the gas for which it has been calibrated. Consequently, calibration checks must be included as part of the routine inspection of the system. The device is labeled with the type and value of the factory calibration gas.
- Use only genuine MSA replacement parts when performing any maintenance procedures provided in this manual. Failure to do so may seriously impair device performance. Repair or alteration of the device, beyond the scope of these maintenance instructions or by anyone other than an authorized MSA service provider, could cause the product to fail to perform as designed.
- This device does not detect the presence of hydrogen gas and must never be used to monitor for hydrogen gas.
- The standard device must never be used in atmospheres containing acetylene gas. Contact MSA regarding available acetylene sensors.
- Calibrate frequently if used in atmospheres exposed to high levels of solvents or dust. See chapters [5 Start-up and Calibration](#) and [6 Maintenance](#) for calibration and cleaning procedures.
- Do not paint the device. If painting is done in an area where the device is located, exercise caution to ensure paint is not deposited on the device. Such paint deposits could interfere with the device operation. Solvents in the paint may also cause an alarm condition to occur.
- The device is designed for applications in hazardous areas under environmental conditions defined in the Specifications section of this manual.
- The response time of the device can be increased by significant dust deposits. Checks for dust deposits must be done at regular intervals.
- The device's sensor will detect other hydrocarbon gases than the target gas.
- Oxygen enriched atmospheres greater than 21 Vol % can affect the measurement and the electrical safety of the Gas Monitor. Do not use the device in these atmospheres.

Failure to follow these warnings can result in serious personal injury or death.

1.4 MSA Permanent Instrument Warranty

Warranty

Seller warrants that this product will be free from mechanical defect or faulty workmanship for

- IR Dual source: ten (10) years from date of shipment, as determined by HART communication that both sources are non-functional
- Gas Monitor, excluding accessories: three (3) years from date of shipment
- Calibration cap: one (1) year from date of shipment

This warranty is applicable provided the product is maintained and used in accordance with Seller's instructions and/or recommendations.

The Seller shall be released from all obligations under this warranty in the event repairs or modifications are made by persons other than its own or authorized service personnel or if the warranty claim results from physical abuse or misuse of the product. No agent, employee or representative of the Seller has any authority to bind the Seller to any affirmation, representation or warranty concerning the goods sold under this contract. Seller makes no warranty concerning components or accessories not manufactured by the Seller, but will pass onto the Purchaser all warranties of manufacturers of such components.

THIS WARRANTY IS IN LIEU OF ALL OTHER WARRANTIES, EXPRESSED, -IMPLIED OR STATUTORY, AND IS STRICTLY LIMITED TO THE TERMS HEREOF. SELLER SPECIFICALLY DISCLAIMS ANY WARRANTY OF - MERCHANT ABILITY OR OF FITNESS FOR A PARTICULAR PURPOSE.

2 Description

The safety function of the device is designed to monitor the environment combustible gas concentration at the installed location and alert the user to potentially dangerous levels of hydrocarbon gas:

- When the hydrocarbon gas concentration $\geq 25\%$ LEL ($\pm 3\%$ LEL), the first alarm relay (NC) shall be closed and the 4-20 mA output signal is 8 - 12 mA
- When the hydrocarbon gas $\geq 50\%$ LEL ($\pm 5\%$ LEL) the second alarm relay (NC) shall be closed and the 4 - 20 mA output signal is 12 - 20 mA

For the safe state of the device please refer to chapter 7. The device is shipped factory calibrated and is labeled with target gas, calibration gas and span setting information.

The output of the device is a standard 4 - 20 mA with HART. The 4 - 20 mA signal communicates the primary measured value using the 4 - 20 mA current loop. Additional device information is communicated using a digital signal that is superimposed on the analogue signal. The device is compliant with HART Communications Foundation (HCF) Revision 7.0 format. Commercially available hand-held communicator devices or PC applications can be used to communicate with the device using the Device Description (DD) file that is available from the HART Communications Foundation website (www.hartcomm.org).

WARNING!

HART communication is non-safety related, therefore it shall never be used in safety related applications.

Failure to follow this warning can result in serious personal injury or death.

2.1 User Interface

This device is equipped with IR sensor connected to a housing with electronics incorporating display and relay output. The display consists of four digits LED with 15 segments to display gas concentration and function or error code.

The gas level and basic device status are available via the 4 - 20 mA output signal. Other detailed device status is available via the HART signal. Details about this interface can be found in the PrimaX IR+ HART Specification on <https://msasafety.info/PrimaXIRPlus>.

The optional calibration cap provides an LCD display for easy and intuitive calibration of the device. The proper usage of this calibration cap is described in chapter [5.2 PrimaX IR+ Calibration](#).

The device should be installed where gas leaks and/or accumulations are anticipated. The installation position depends on the gas density, either in the upper area of the room beneath the ceiling for gases lighter than air, or close to the ground for gases heavier than air. Also consider how air movement may affect the ability of the device to detect gas. Testing for ventilation patterns may be helpful in establishing locations for the device in enclosed areas.



Before beginning the installation, check that the delivered components are complete and correct, referring to the shipping documents and the label on the shipment carton.

2 Description

Figure 1 Device LED and Display



- | | |
|---------------|----------------------------|
| 1 Display | 4 Remote controller IR LED |
| 2 Warning LED | 5 Fault LED |
| 3 Alarm LED | 6 Normal status LED |

2.2 Package Contents

The device will be delivered with the following items in the shipping carton:

- PrimaX IR+ Gas Detector or PrimaX IR+ Display Housing and PrimaX IR Sensor or PrimaX IR+ Display Housing (Aluminum or 316 Stainless Steel) and PrimaX IR Sensor (316 Stainless Steel)
- Environmental guard
- Quick Start Guide
- This instruction manual, HART specification and installation drawing
- Mounting kit

Figure 2 Overview

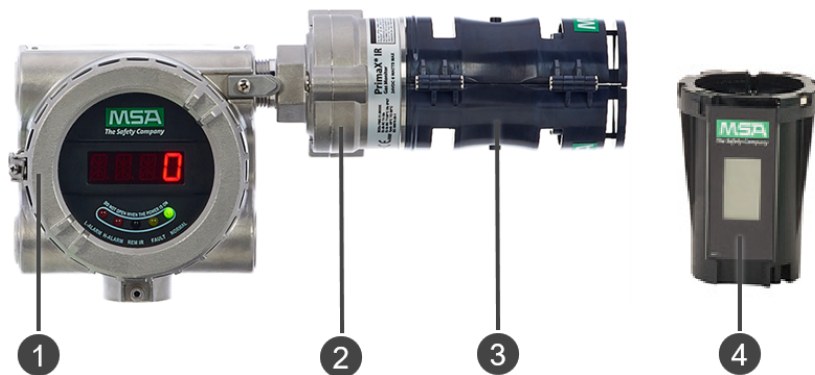

- | | |
|-----------------------------------|------------------------------|
| 1 Housing (aluminum or stainless) | 3 Environmental guard |
| 2 Sensor (316 stainless steel) | 4 Calibration cap (optional) |

Accessories to be used with this product may be packaged separately. Check the enclosed shipping papers to identify all PrimaX IR+ accessories that have been ordered.

Accessories available for the PrimaX IR+ Gas Monitor include:

- Optional calibration cap for calibration operations
- Optional tether strap for environmental guard
- Optional IR-Control remote controller

For complete list of accessories see chapter [8 Ordering Information](#).

The device will be labeled with the information shown below:

- Target gas, calibration gas and span value
- Serial number and date of manufacture
- Area classification markings

3 Installation

3.1 Mechanical Installation

The device's dimensions are shown below in mm (inches):

Figure 3 Dimensions (stainless steel version is shown)

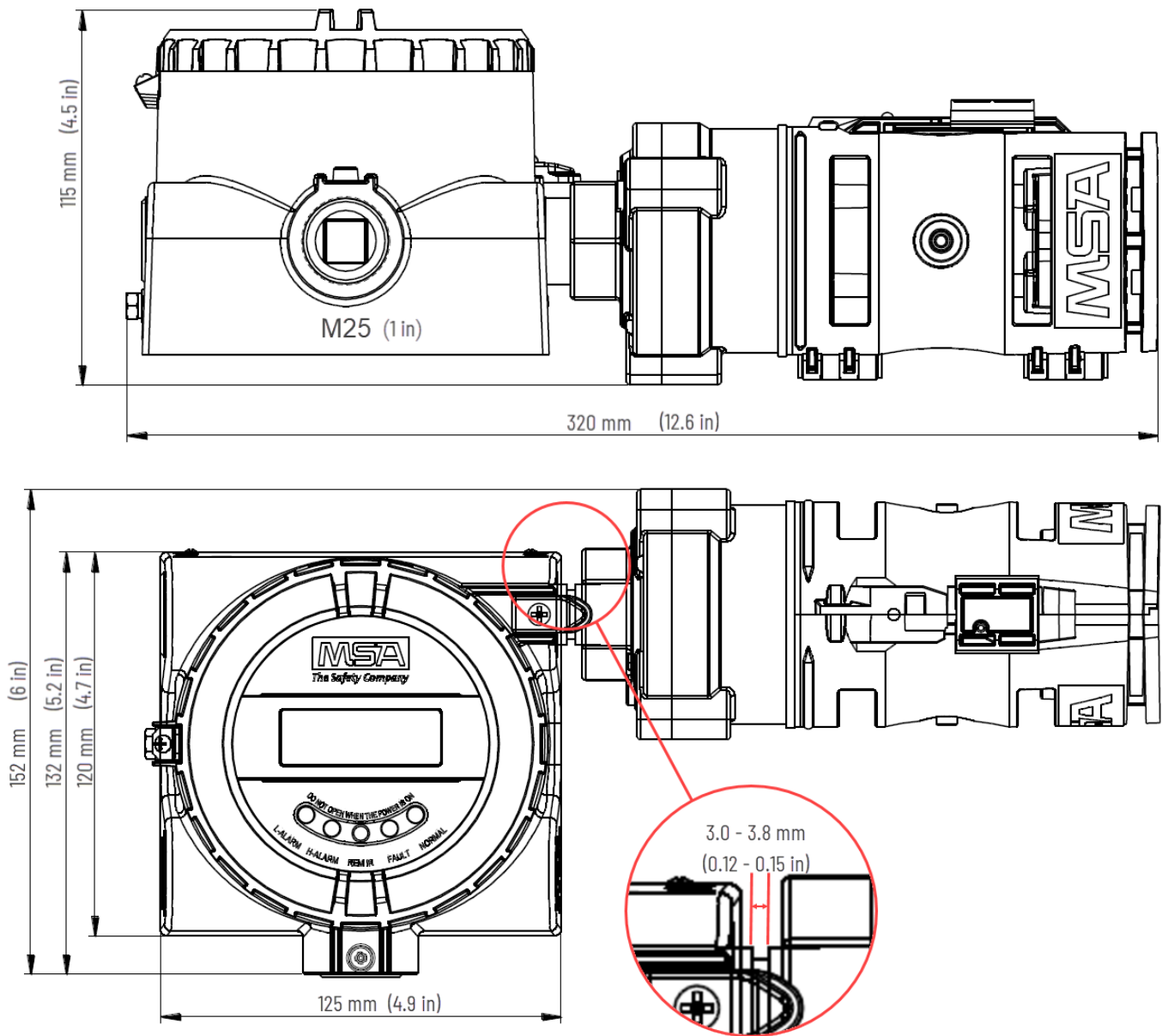

Figure 4 Junction box



WARNING!

- Mount the device with the sensor inlet fitting extended horizontally from the main enclosure (→ [Figure 5](#)) to reduce the potential for the build-up of particulate or liquid matter on the monitor's optical surfaces.
- Insert gasket between IR sensor conduit nipple and display enclosure, and compress 3.0 to 3.8 mm to ensure proper Ingress Protection (→ [Figure 3](#)).
- Do not paint the device. If painting is done in an area where a sensor is located, exercise caution to ensure paint is not deposited on the sensor. Such paint deposits could interfere with the device operation. Solvents in the paint may also cause an alarm condition to occur.
- Protect the device from extreme vibration.
- Do not mount the sensing head in direct sunlight without a sunshield since this may cause the sensor to overheat.

Failure to follow these warnings can result in serious personal injury or death.

Figure 5 Recommended Mounting Orientation



1 Hex nut size: 36 mm - metric

NOTICE

During sensor installation or removal, do not use any tools or apply excessive force to the two legs that support the unit's reflectors. Applying force to the legs can permanently damage the monitor.

MSA recommends that the device's environmental guard should be installed on the sensor at all times. If the device is to be operated without the guard, frequent checks must be made to ensure particulate or liquid matter has not collected on the windows.

1. Use a 36 mm wrench on the hex nut in the sensor neck to install or remove the sensor.
 - Do not apply torque to the two sensor legs.

3 Installation

Figure 6 Exploded View of PrimaX IR+ Mounting

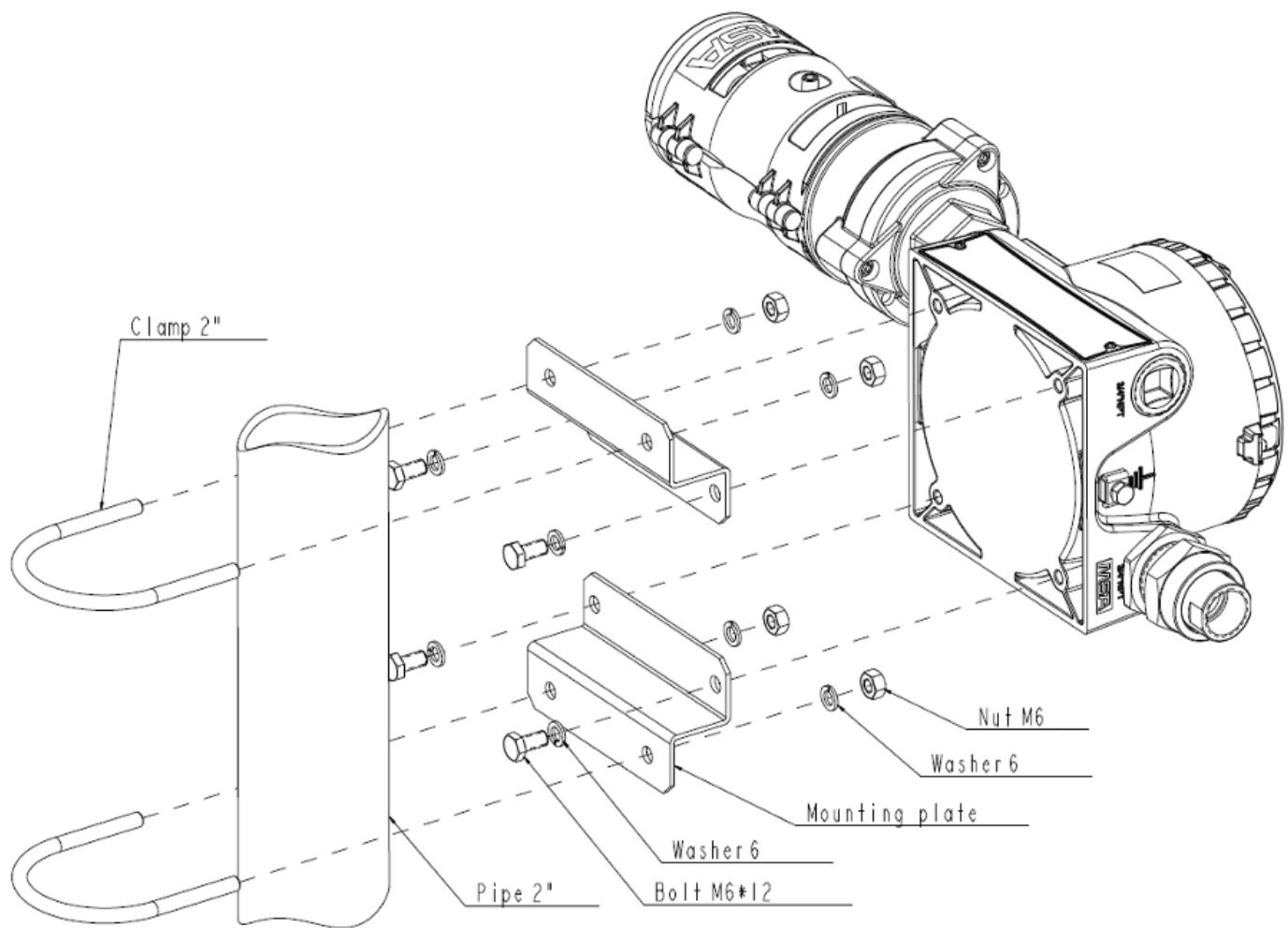

Optional Remote Junction Box Instructions

If installing the sensor on a junction box, verify that the junction box area classification is appropriate for the installation environment. Two options are available for MSA junction boxes:

- Powder-coated Aluminum
- 316 Stainless Steel

A stainless steel mounting plate is included with the PrimaX IR+ housing to ensure sufficient clearance from the installed surface (→ [Figure 6](#)).

1. Install the mounting bracket and PrimaX IR+ using the bracket holes as the drilling template (→ [Figure 7](#)).

Figure 7 Mounting Bracket

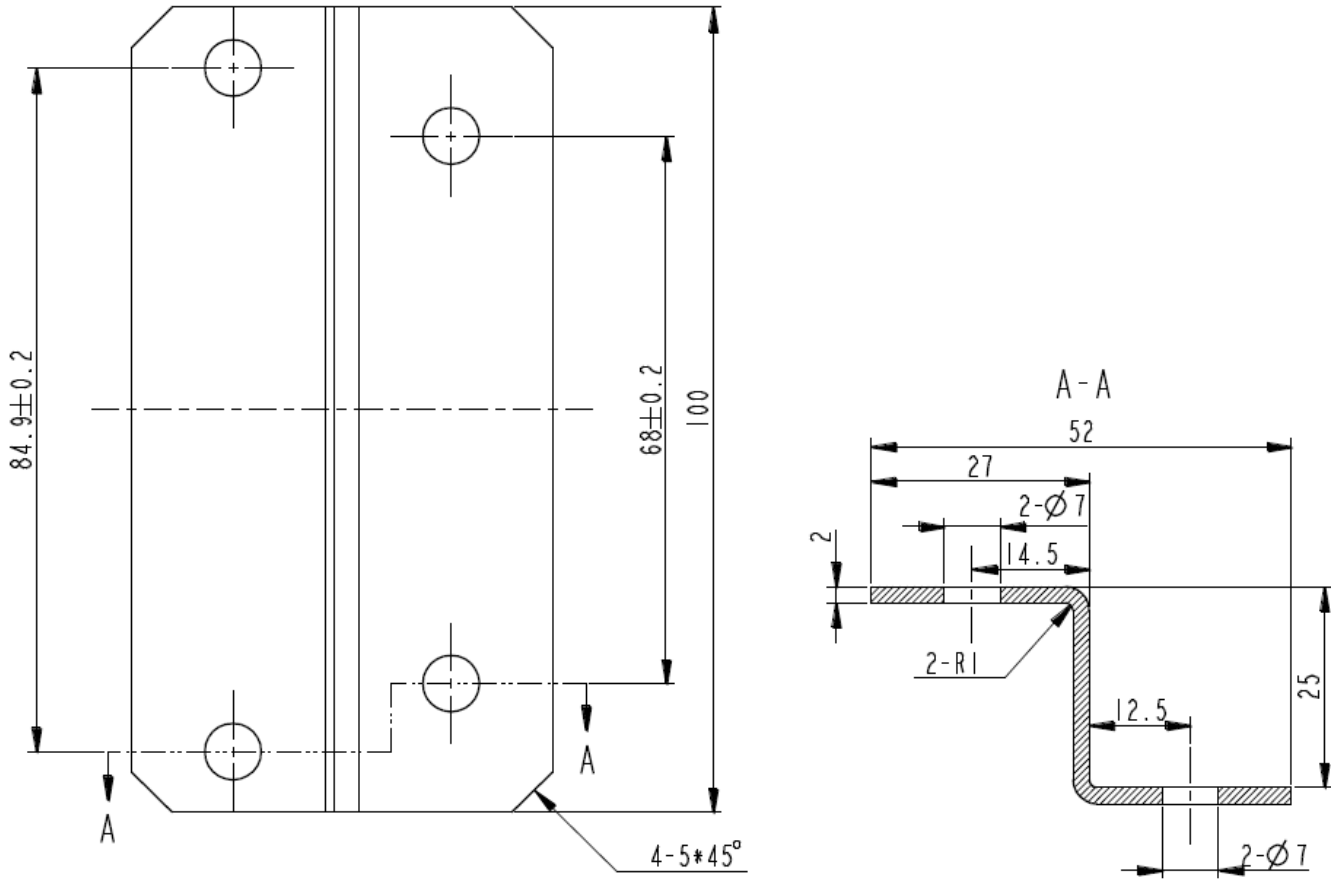

2. The optimum orientation for the device is horizontal.

When deploying the optional remote junction box, the PrimaX IR sensor can be mounted up to 30 m (100') from the PrimaX IR+ display housing. Please see section [3.2 Electrical Installation](#) for additional details

3.2 Electrical Installation

Instructions for Electrical Connection

⚠ WARNING!

- The device must be installed only in compliance with the applicable regulations, otherwise it may not operate as intended. Proper installation should prevent water and dirt from entering the unit via the wires or conduit.
- Before wiring the device, disconnect the power source supplying the device and ensure no hazardous atmosphere present; otherwise, electrical shock or ignition of a hazardous atmosphere could occur.
- The power port must be powered by a regulated 24 VDC SELV/PELV power supply.
- Install wiring in accordance with the electrical code of the country in use, the local authority having jurisdiction and these installation instructions, as applicable.
- Do not make any connections to the device main board or junction box input, output, and relay connections while under power. Making connections under power could lead to electrical shock or ignition of a hazardous atmosphere.
- Ensure that water and dirt are not able to enter the unit via the wire or conduit. If the unit is installed in a location known to be wet or damp, it is good practice to loop or bend the entry into the unit that prevents water incursion.
- The internal grounding terminal located in the base of the transmitter enclosure must be used for equipment grounding. The external grounding terminal is only to be used as a supplemental bonding connection where local authorities permit or require such a connection.
- Never remove or replace a Sensor while under power or when explosive hazards are present.

Failure to follow these warnings can result in serious personal injury or death.

Shielded cable for measuring devices is recommended.

Always observe maximum cable lengths and cross-sections shown below.

Wiring Requirements

Refer to table on installation I/O drawing for wire lengths and sizes required for proper installation. The HART signal requires a load resistor across the signal.

The device sensor is provided with 4 wires for use. The table below shows the wire color definitions:

Table 1

Wire Color	Definition
Red	24 VDC (DC +)
Yellow	4 ~ 20 mA Source (SIG)
White	0 VDC (DC -)
Green/Yellow	Earth Ground

Power Supply Requirements

An external 24 VDC SELV/PELV power source is required. Use a high quality, DC power supply with low noise characteristics. See the diagram below for power supply and wiring details:

	Power requirements	
	Nominal	Maximum
Input voltage (at sensor)		
20 V DC	220 mA	350 mA
24 V DC	175 mA	250 mA
30 V DC	130 mA	200 mA

NOTICE

The device signal cables shall be permanently connected (fixed) and protected against external damage, e.g. by:

- cable conducting, or
- armouring, or
- using separate multi-core cables, or
- within an electrical enclosure, or
- individually shielded with earth connection.

Figure 8 Wiring Diagram

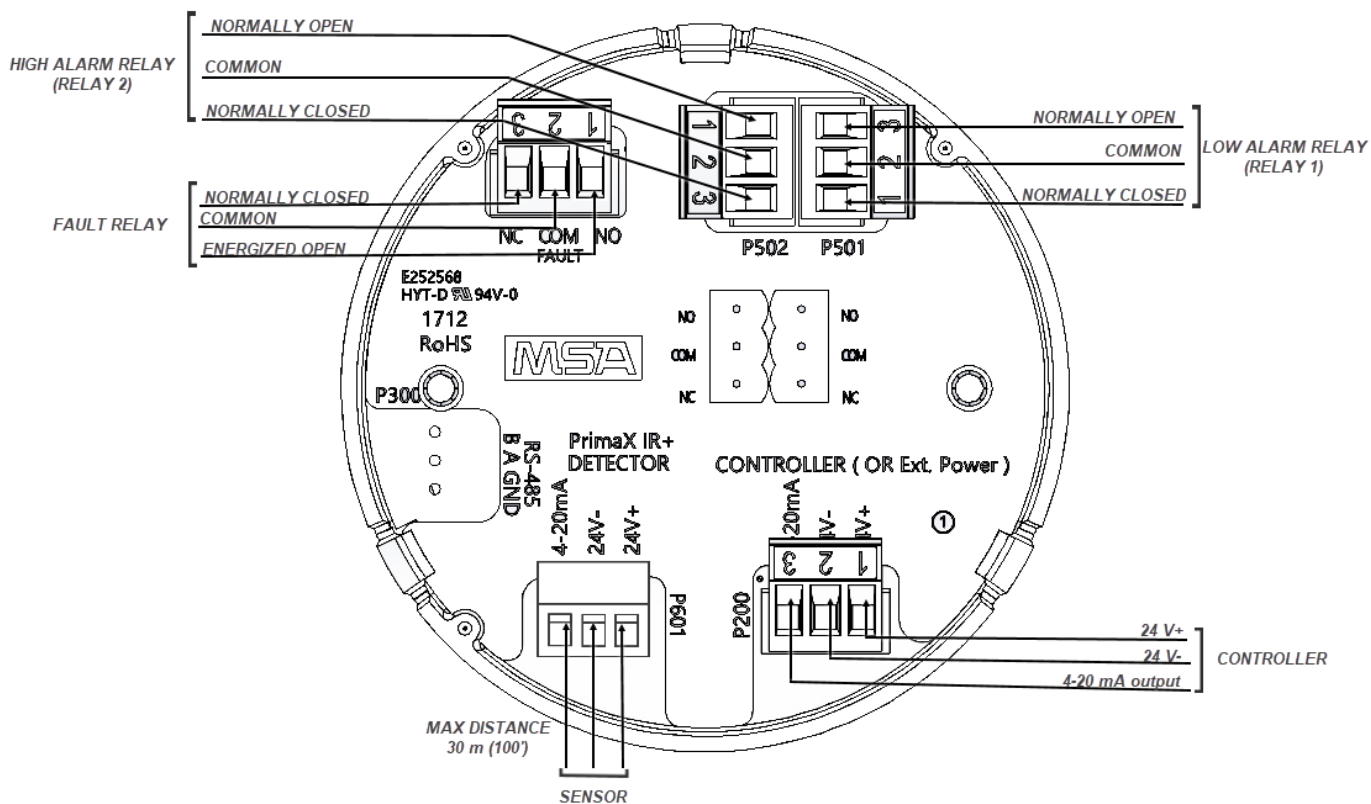

3 Installation

Figure 9 PrimaX IR Aluminum Junction Box with Sensor Connected

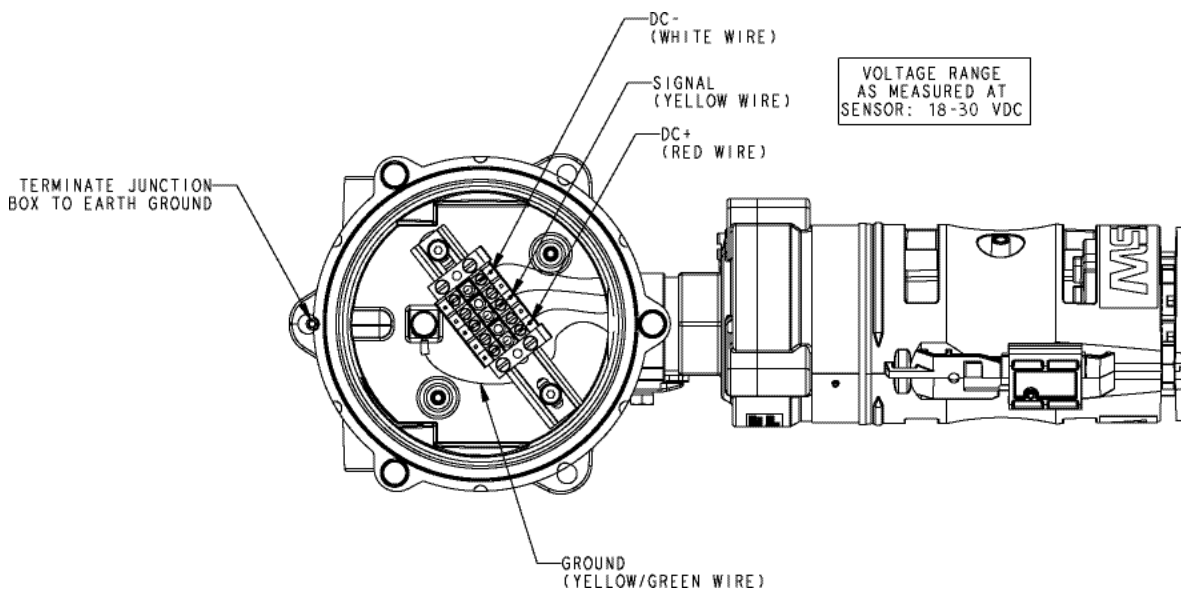

External Controllers

The device can be connected to any device capable of accepting a 4 - 20 mA sourcing analog signal. Ensure that the controller can read all signals. See www.MSAafety.com for available controllers.

The HART output is intended to be used with digital control systems that are compatible with HCF Revision 7.0 protocol.

4 Remote Controller and Menu Sequence

4.1 Remote Controller (sold separately)

Figure 10 Remote Controller



- 1 **ON**: Enter one menu item/Save 2 **OFF**: Exit/Abandon modification
 3 **+**: Up roll menu item/Increase value 4 **-**: Down roll menu item/Decrease value

Buttons

The main function of the 4 buttons used for navigation of the menu sequence:

- **+** or **-** is used for navigation of the menu or increasing or decreasing data.
- **ON** is used to enter the submenu of menu items M-01, M-02, etc, or ready to modify data, or to save data.
- **OFF** is used to exit menu items M-01, M-02, etc, or to abandon modification of the data.

4.2 Menu Item

Menu Item	Function	Password Need
M-00	Reset Relay	Yes
M-01	Parameter Viewing	No
M-02	Parameter Setting	Yes
M-03	New Password Setup	Yes
M-04	Load default	Yes
M-05	LED test	No

NOTE: In the description of the following menu function. "Measure mode" means concentration display mode.

(M-01) - Parameter Viewing

1. Switch to the measure mode.
2. Press button "+" to select M-01.
3. Press button "ON".
 - The displays shows the next submenu.

Display Contents of the Submenu Item	Meaning
ALARM_1=XX	Low alarm point
ALARM_2=XX	High alarm point
ALARM RELAY2 = DENE/ENER	Low Alarm relay energized / de-energized
ALARM RELAY2 = DENE/ENER	High Alarm relay energized / de-energized
ALARM RELAY1 = LTCH/ULTH	Low Alarm relay latch / un-latch
ALARM RELAY2 = LTCH/ULTH	High Alarm relay latch / un-latch
TEMP = XX	Display the current temperature of PCBA
SLAVE ADDR = 1	Default always 1

(M-02) - Parameter setting

1. Press button “+” to select M-02 in the measure mode.
2. Press button “ON” on the remote controller to enter the submenu.
3. Enter password: (Default = 0000)
 - The password has four digits.
 - The first of the four digits starts blinking.
4. To change the value, press button “+” or “-” to increase or decrease data.
5. Press button “ON” after changing value to save data.
 - The first of the four digit stops blinking.
 - The second digit starts blinking.
6. Repeat procedure for all left digits.

NOTE: If the password is correct, the displays shows the next submenu. If the password is wrong, the display returns to the menu M-02.

Display Character of the Submenu Item	Meaning
ALARM_L= XX	Low alarm point 5% ~ (configured high alarm threshold-1%)
ALARM_H= XX	High alarm point (configured low alarm threshold+1%) ~ 99%
ALARM RELAY2 = DENE/ ENER	Low Alarm relay energized / de-energized
ALARM RELAY2 = DENE/ ENER	High Alarm relay energized / de-energized
ALARM RELAY1 = LTCH/ULTC	Low Alarm relay latch / un-latch
ALARM RELAY2 = LTCH/ULTC	High Alarm relay latch / un-latch
TEMP SETTING = XX	Temperature sensor calibration
SLAVE ADDR = 1	Slave address not applicable, leave at 1.

NOTE: Latch relay will cause relay to remain active until manually reset even if gas condition returns to normal. Un-Latch relay will cause relay to reset automatically if gas condition returns to normal.

Changing parameters is similar to the password input:

1. Press button “ON”.
 - The highest digit starts blinking.
2. To change the value, press button “+” or “-” to increase or decrease data.
3. Press button “ON” after changing value to save data.
4. Repeat procedure for all left digits.
5. Press “+” to proceed to next parameter setting.

(M-03) - New password setting (default value is 0000)

1. Press button “+” to select M-03 in the measure mode.
2. Press button “ON” on the remote controller to enter the submenu.
3. Enter password:
 - The password has four digits.
 - The first of the four digits starts blinking.
4. To change the value, press button “+” or “-” to increase or decrease data.
5. Press button “ON” after changing value to save data.
 - The first of the four digit stops blinking.
 - The second digit starts blinking.
6. Repeat procedure for all left digits.

NOTE: If the password is correct, the display shows the next submenu. If the password is wrong, the display returns to the menu M-03.

Display Character of the Submenu Item	Meaning
NEW PASSWORD	Input new password

Changing parameters is similar to the password input:

1. Press button “ON”.
 - The highest digit starts blinking.
2. To change the value, press button “+” or “-” to increase or decrease data.
3. Press button “ON” after changing value to save data.
4. Repeat procedure for all left digits.

(M-04) - Load default

1. Press button “+” to select M-04 in the measure mode.
2. Press button “ON” on the remote controller to enter the submenu.
3. Enter password:
 - The password has four digits.
 - The first of the four digits starts blinking.
4. To change the value, press button “+” or “-” to increase or decrease data.
5. Press button “ON” after changing value to save data.
 - The first of the four digit stops blinking.
 - The second digit starts blinking.
6. Repeat procedure for all left digits.

NOTE: If the password is correct, the detector will restart. If the password is wrong, the display returns to the menu M-04.

Factory default mode:

- Low alarm: 25% (safety function)
- High alarm: 50% (safety function)
- High/low alarm relay: Energized state (relay contact is closed) (Safety Function)
- Unlock, password reset to 0000
- Temperature offset value = Factory default, Do Not Change

4 Remote Controller and Menu Sequence

- Slave Addr =1 Factory default, Do Not Change

(M-05) - LED test

1. Press button "+" to select M-05 in the measure mode.
2. Press button "ON" on the remote controller to enter the submenu. Then detector display "OFF"
3. Press button "+" one time, all LED will flash. Press button "+" again, detector display "OFF", the LED stop flash.

NOTE: Press the Button "OFF" to cancel the input during the process.

5 Start-up and Calibration

5.1 Remote Controller and Menu Sequence

5.1.1 Initial Start-up

The device is factory-calibrated and ready for use. The device provides a 4 - 20 mA output signal that can be used in conjunction with data acquisition controllers. The digital HART signal that is superimposed on the 4 - 20 mA output can be read by control systems that are in compliance with HART Revision 7.0 format.

During device operation, the fault information shown below:

Table 2

Fault Code	Analog Output	Description	Meaning
E-01	0.0 mA	Safety Critical Fault	Sensor Failure
E-02	2.0 mA	General Fault	Instrument fault
E-03	2.5 mA	Dirty Optics	Dirty sensor optics
E-04	3.0 mA	Power Up - Sensor Calibration	Start-up/Calibration
E-05	3.5 mA	Cleaning Mode	Sensor cleaning mode (defined in chapter 6.4 Cleaning)
E-06	20.5 mA	Overrange	Sensor Overrange

Fault Code	Description	Meaning
E-07	Flash - Self Check Fault	Power on Flash Check failed
E-08	RAM - Self Check Fault	Power on RAM Check failed
E-09	CRC Fault	CRC on information block failed
E-10	WDT Fail	Watchdog failure
E-11	ADC Fault	ADC measurement failure
E-12	Temp Sensor Fail	Temperature failure
E-13	Relay Fault	Relay failure
E-14	Task Fault	Task fault
E-15	Relay SPI Fault	SPI relay comms failure
E-16	Information Flash Write Fault	Flash write failure
E-17	External Reference Check Fault	External reference out of range
E-18	Periodic Flash Check Fault	Periodic flash CRC failure
E-19	Periodic RAM Check Fault	Periodic RAM check failure
E-20	ADC12 Stuck High Fault	ADC12 stuck high
E-21	ADC10 Stuck High Fault	ADC10 stuck high
E-22	Periodic PC Check Fault	PC check failure
E-23	Periodic Stack Check Fault	Stack check failure
E-24	Periodic Register Check Fault	General register check failure
E-25	Periodic SFR Check Fault	Special function register check failure
E-26	Periodic Voltage Check Fault	Failed voltage check
E-27	Interrupt Fault	Interrupt error
E-28	RAM Data Fault	RAM data failure

5 Start-up and Calibration

During device operation, the 4 - 20 mA output signal is updated once/second and provides the information shown below:

4-20 mA Output Levels (Default Values)		
OPERATION	4 - 20 mA	Definition
SAFETY CRITICAL FAULT	0.0 mA	Sensor failure. Communications not available to sensor
*FAULT	2.0 mA	Problem detected. Status available via HART interface
*OBSCURATION OR DIRTY OPTICS	2.5 mA	Light path is blocked
*POWER UP OR -SENSOR - CALIBRATION	3.0 mA	Unit power was recently applied or calibration in process with Cal Signal Enabled
*CLEANING MODE	3.5 mA	Defined in chapter 6.4 Cleaning
NORMAL	Gas value scaled from 4 - 20 mA for 0 - 100 % LEL	
OVERRANGE	20.0 - 20.5 mA	> 100 % LEL gas is detected by the device

* Output levels are customer configurable between 2.0 - 3.5 mA via the HART interface See the PrimaX IR HART specification document (10125187), which can be found on the product page <https://msasafety.info/PrimaXIRPlus>, for more information.

Transient Fault conditions will be automatically cleared when the unit recovers from the fault condition.

MSA recommends verifying proper response to changes in mA outputs by using the "Enter Fixed Current Mode" command described in the PrimaX IR Link Help Guide to check the four fault conditions noted with a * above. These checks should be done at every calibration phase.

Calibrations

WARNING!

- Read all calibration instructions before attempting an actual calibration.
- Use zero gas when zeroing the device if there is any possibility of background gas. Otherwise, improper calibration could occur.
- For optimal sensor performance, allow sensors to acclimate to application conditions before performing an initial calibration.
- Perform calibrations 24 hours after initial start up and at regular intervals as detailed in this manual.
- You must calibrate the PrimaX IR sensor with either the target gas or the Span Gas indicated in [Table 3](#) for the sensor to be accurate for the target gas.
- The device must be calibrated after changing the gas table and/or span value.

Failure to follow these warnings can result in serious personal injury or death.

Identify and become familiar with all of the calibration components. Assembling the calibration components **before** starting the calibration process will make it easier. Carry out the calibration during commissioning as well as at regular intervals. This ensures optimum operation of the sensor.

The calibration must be done at regular intervals in accordance with applicable national and regional regulations.

The device is calibrated at the factory. Nevertheless, it is recommended to recalibrate the device after installation. New sensors shall be calibrated more often until the calibration records prove sensor stability.

The calibration frequency can then be reduced to the schedule set by the safety officer or plant manager.

Signal

NOTE: Before attempting calibration the device should be powered for at least 60 minutes to allow for temperature stabilization.

The 4 - 20 analogue signal is available within 1 minute of power-on.

NOTE: It is recommended that all calibration components are connected before starting a calibration as it is necessary to apply test gas at the appropriate time (→ [Figure 17](#)).

Although the device is factory-calibrated, it is good practice to calibrate the unit once it is installed in its final environmental destination.

As with any type of gas monitor, the only true check of its performance is to apply gas directly to the sensor. New sensors should be calibrated more often until the calibration records prove sensor stability. The calibration frequency can then be reduced to the schedule set by the safety officer or plant manager.

For span gas selections see chapter [5.3 Calibration Kits](#).

5.2 PrimaX IR+ Calibration

The device can be calibrated using either the optional calibration cap locally at the sensor, or using the HART digital interface.

NOTE: MSA recommends using a calibration gas value in the middle of the measuring range for optimum calibration.

Calibration Methods

⚠ WARNING!

The standard environmental guard is designed to offer fast response time and must not be used for bump or calibration without the Remote Calibration Inserts (see chapter 8 [Ordering Information](#), P/N 10122783). Failure to do so could dilute the sample and result in inaccurate calibration.

Failure to follow this warning can result in serious personal injury or death.

Figure 11 MSA Calibration Cap



Figure 12 Remote HART Calibration Kit



Figure 13 HART Hand-held (by other providers)



Although both a full calibration (zero and span) and zero only calibration can be performed on the device, a zero only calibration may be sufficient to properly calibrate the monitor. Normally, any degradation of the sensor's performance is

associated with slight drifts in zero that, in turn, will adversely affect its span performance. After completing the zero calibration, perform a span check to ensure proper operation. For a span check, apply a gas of known concentration and verify that the measured response is within acceptable limits. If the span check is unsuccessful, perform a full zero and span calibration.

Alternate Span Gas Settings

To achieve the most accurate calibration it is always best to use the gas of interest and calibrate at the operating temperature. If the target span gas is not available, an alternative span gas can be used with the values show in the table below. The sensor label will identify the span gas and value used by the factory for calibration. Use of a reference gas for calibration may decrease accuracy. The user may change the gas monitor's span value, gas name and gas curve through use of the PrimaX IR+ Link software found on <https://msasafety.info/PrimaXIRPlus>. Please refer to the PrimaX IR HART Specification and the PrimaX IR+ Link Help Guide on <https://msasafety.info/PrimaXIRPlus>.

5 Start-up and Calibration

Table 3 Calibration Settings

Target Gas	100% LEL ¹	Performance Approved Range	Measuring Range	Calibration Gas	Span Value ²	t50	t90	Gas Cal Curve No.
Methane	4.40%	0-100%	0-100%	2.5% v/v Methane	57%	≤ 7 s	≤ 15 s	1
Methane	5.00%	0-100%	0-100%	2.5% v/v Methane	50%	≤ 7 s	≤ 15 s	1
Propane	1.70%	0-100%	0-100%	0.6% v/v Propane	35%	≤ 7 s	≤ 15 s	2
Propane	2.10%	0-100%	0-100%	0.6% v/v Propane	29%	≤ 7 s	≤ 15 s	2
Toluene	1.00%	0-30%	0-100%	2.5% v/v Methane	57%	≤ 11 s	≤ 28 s	3
Toluene	1.10%	0-30%	0-100%	2.5% v/v Methane	52%	≤ 11 s	≤ 28 s	3
n-Butane	1.40%	0-30%	0-100%	0.6% v/v Propane	37%	≤ 10 s	≤ 24 s	2
n-Butane	1.50%	0-30%	0-100%	0.6% v/v Propane	35%	≤ 10 s	≤ 24 s	2
Acetone	2.50%	0-100%	0-100%	2.5% v/v Methane	44%	≤ 11 s	≤ 25 s	2
Propylene	2.00%	0-50%	0-100%	1.0%v/v Propylene	50%	≤ 11 s	≤ 25 s	3
Propylene Oxide	1.90%	0-100%	0-100%	2.5% v/v Methane	19%	≤ 11 s	≤ 25 s	3
Propylene Oxide	2.30%	0-100%	0-100%	2.5% v/v Methane	16%	≤ 11 s	≤ 25 s	3
Ethane	2.40%	0-50%	0-100%	1.2%v/v Ethane	50%	≤ 11 s	≤ 23 s	3
Ethylene	2.30%	0-100%	0-100%	1.35% v/v Ethylene	59%	≤ 10 s	≤ 23 s	3
Ethylene	2.70%	0-100%	0-100%	1.35% v/v Ethylene	57%	≤ 10 s	≤ 23 s	3
Cyclopentane	1.40%	0-100%	0-100%	0.6% v/v Propane	35%	≤ 10 s	≤ 25 s	2
Cyclopentane	1.50%	0-100%	0-100%	0.6% v/v Propane	33%	≤ 10 s	≤ 25 s	2
Isobutane	1.30%	0-70%	0-100%	0.65%v/v IsoButane	50%	≤ 12 s	≤ 26 s	2
Isobutane	1.80%	0-70%	0-100%	0.6% v/v Propane	39%	≤ 12 s	≤ 26 s	2
Ethyl Acetate	2.00%	0-100%	0-100%	2.5% v/v Methane	21%	≤ 12 s	≤ 25 s	2
n-Hexane	1.00%	0-10%	0-100%	0.5%v/v n-Hexane	50%	≤ 11 s	≤ 24 s	2

Target Gas	100% LEL ¹	Performance Approved Range	Measuring Range	Calibration Gas	Span Value ²	t50	t90	Gas Cal Curve No.
n-Pentane	1.10%	0-30%	0-100%	0.55%v/v n-Pentane	50%	≤ 11 s	≤ 24 s	2

¹ IEC/UL/EN 80079-20-1 was used as bases for converting test and calibration gas concentrations from % LEL to % volume fraction

² For the measurement of n-Pentane, n-Hexane, Propylene, Ethane or Isobutane PrimaX IR shall be calibrated with the target gas at a span value of approximately 50% LEL.

Calibration Cap Procedure

1. Remove the environmental guard from the device.
2. The calibration cap is equipped with a slot for an optional tether retention system. The figure below shows the location of the tether slot.

Figure 14 Calibration Cap



1 Tether slot

3. If the user can confirm that the ambient air is free of combustible gas, ambient air can be used in place of the zero gas cylinder. For a visual representation of the calibration process see (→ [Figure 17](#)).
4. Install the calibration cap. Press firmly to ensure cap is properly seated.
 - The calibration process will start automatically when the cap is fully seated on the sensor housing.
 - Under normal conditions, the display will show all icons steady at power-up.
5. The calibration cap display indicates the zero gas cylinder symbol and flashes, indicating that the device is in Zero Calibration mode.
 - The initial 30 seconds is intended to give the user time to apply gas to the sensor. During this time, the user can abort the process by removing the calibration cap.
 - After the initial 30 seconds, the device will start the Zero calibration adjustment. The Zero Calibration is indicated by the white cylinder (→ [Figure 15](#)) and the word "Zero".
 - Removal of the calibration cap after the initial 30 seconds will result in a calibration fault. This will abort the present calibration and the device will continue to operate with the previous calibration settings.
6. Apply zero gas to the calibration port at an approximate flow rate of 1.5 LPM while the cylinder symbol is flashing. Zero gas can be supplied as ambient air or from the zero gas cylinder in the calibration kit (→ [5.3 Calibration Kits](#)).

Figure 15 Zero Gas Cylinder Symbol



7. When the Zero calibration is successful, the tick symbol "✓" will appear. If only performing a Zero calibration, remove the calibration cap. Following a successful zero, the span process will automatically begin within 30 seconds following the zero symbol "✓".
8. If the Zero calibration fails, the display will show an X for approximately 2 minutes, and will then power down.
 - If the Zero calibration fails, remove the calibration cap and reinstall to start another zero attempt. If multiple failures occur, contact an authorized MSA service center.
9. When the display flashes the span gas symbol, apply the span gas through the calibration cap port (→ [Figure 11](#)).
 - The unit must see gas within 30 seconds after the span symbol starts to flash or a calibration fault may occur. The initial 30 seconds are intended to give the user time to apply gas to the sensor. During this time, the user can abort the Span process by removing the calibration cap.
 - The display will then flash at a faster rate to indicate active calibration by the sensor.

Figure 16 Span Gas Cylinder Symbol



10. When the Span calibration is successful, the tick symbol "✓" will appear. If the Span calibration fails, an "X" will be displayed for approximately 2 minutes, and the device will then power down.
 - See chapter [6 Maintenance](#) for subsequent action upon calibration failure.
11. When calibration is complete, stop the gas flow and remove the calibration cap. Reconnect the environmental guard or flow cap to the sensor. The calibration cap will automatically power down once removed from the sensor. The 4 - 20 mA is held at the sensor calibration level for two minutes to reduce the chance of a nuisance alarm upon completion of a calibration procedure.
 - During calibration and this 2 minute period, the unit will not be detecting any gas in the ambient area.
 - Alternately, the device can be commanded via HART to track the gas level during calibration (see the Calibration Signal Enable/Disable command in the HART Specification).
 - Once the calibration cap is removed it can take up to two minutes for gas to diffuse and the device to read normal ambient levels.

Steps 5-11 are shown below:

Figure 17 Calibration Cap Sequence of Events

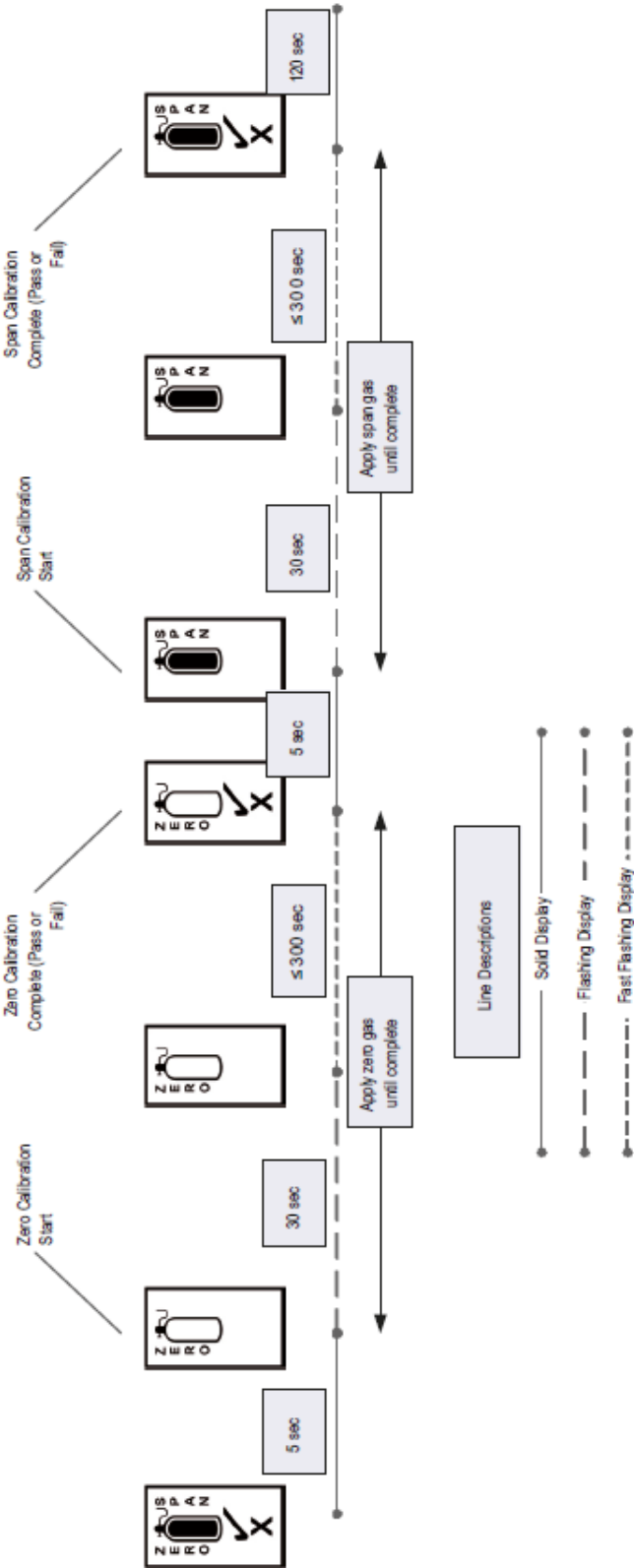

5 Start-up and Calibration

When a Zero or Span calibration failure occurs, the device reverts back to its previous successful calibration settings.

If the calibration cap is left on for more than 15 minutes after calibration concludes, the 4 to 20 mA signal indicates Fault status.

When the calibration cap battery is nearing the end of its useful life, the LCD will display all the icons in a series of rapid flashes at power-up before it starts the normal calibration cycle. The battery is non-serviceable and the calibration cap would need to be replaced once the battery is depleted.

⚠ WARNING!

The calibration cap must be removed from the device after completing the Zeroing and/or Spanning procedure. Failure to do so could restrict gas flow to the sensor and result in erroneously low readings.

Failure to follow this warning can result in serious personal injury or death.

HART Calibration Procedure

The device can be calibrated using a HART compatible communications interface with Device Description capability (DD), such as the Emerson 375 or 475 Field Communicator (→ [Figure 13](#)). Ensure that the HART hand-held communicator is compatible with the area classification. This hand-held HART communicator must be HART revision 7.0 compliant and can be obtained from a HART authorized supplier. See the PrimaX IR HART specifications document (10125187), which can be found on the product page <https://msasafety.info/PrimaXIRPlus>, for more information.

Calibration can also be performed via the HART interface with optional screen inserts in the Environmental Guard. The environmental guard can be fitted with these screens that will allow the calibration gas to be retained in the enclosure long enough for a valid zero and/or span reading to be obtained under still-air conditions (→ [Figure 18](#)).

⚠ WARNING!

Use of the insect screens can increase the sensor response time to ambient gas conditions. Ensure that the conditions are appropriate for use of these screens.

Failure to follow this warning can result in serious personal injury or death.

When supplying tubing to the environmental guard to allow remote HART calibration, gas should be delivered to both ports of the environmental guard from a 1.5 l/min regulator (→ [Figure 18](#)):

Figure 18 HART Calibration Set-up



1 Insect screens

When used under windy conditions, a calibration cover must be used instead of the environmental guard while applying the zero and span gas.

For a picture of the cover see [Figure 19](#) .

Figure 19 HART Calibration Cover



⚠ WARNING!

Ensure that the calibration cover is removed after calibration is complete. This cover is intended to block the flow of ambient air into the sensor during calibration, and in normal operation must ALWAYS be removed.

Failure to follow this warning can result in serious personal injury or death.

For applications where access to the HART signal is needed in hazardous areas, MSA provides the HART junction box with intrinsically safe HART port (→ [Figure 20](#)).

Figure 20 HART Module



The explosion-proof port allows access via a HART hand-held controller using the cable shown above (part number 10081441).

5.3 Calibration Kits

Calibration kits are available for the device. The recommended calibration kits are shown in the following table.

Table 4

Gas Type	CAL Cylinder	Cylinder P/N	Span Value	CAL KIT #
Methane	2.5% Methane	10177546	57% LEL (LEL=4.4% vol)	40
Propane	0.6% Propane	10028034	35% LEL (LEL=1.7% vol)	40
Zero Gas	100% Nitrogen	10188082	0% LEL	40

See <https://msasafety.info/PrimaXIRPlus> for additional PrimaX IR+ calibration gases.

6 Maintenance

6.1 General

WARNING!

- All maintenance procedures must be performed on a clean surface using clean tools. Avoid touching the lamp's window as well as the metalized portion of the Cell Assembly with bare fingers. Fingerprints left on these parts may adversely affect the sensors operation. Latex gloves are recommended, but if they are not used, hands must be clean and free of oils, lotions, etc. It is acceptable to hold the lamp by its glass body or by the edges of the window.
- Before working on the device, turn off the power and secure against restart. Ensure no hazardous atmosphere is present. Otherwise electrical shock or ignition of a hazardous atmosphere could occur.
- Remove and reinstall sensors carefully, ensuring that the components are not damaged; otherwise device intrinsic safety may be adversely affected, wrong readings could occur, and persons relying on this product for their safety could sustain serious personal injury or death.

Failure to follow these warnings can result in serious personal injury or death.

There are NO field repairable internal components for this IR sensor. Return to MSA for warranty replacement per the Warranty section [1.4 MSA Permanent Instrument Warranty](#).

Do not attempt to open the enclosure of the IR sensor, it is factory sealed for protection from hazardous environments. If the troubleshooting guides in chapters [6.2 Troubleshooting](#) and [6.3 HART Information for Troubleshooting](#) do not alleviate the problem, contact your MSA representative.

6.2 Troubleshooting

The 4 - 20 mA output provides a limited set of information for diagnostic purposes. Additional troubleshooting steps are outlined below.

Table 5 General Troubleshooting Guide

Indication	Action
Sensor IR source does not flash	Verify sensor and facility wiring according to the installation section and then reapply power
Sensor IR source is flashing but no 4 - 20 mA signal	Verify sensor and facility wiring according to the installation section and then reapply power.
FAULT mA output	Check power supply and restart. Check to ensure that the calibration cap was not left on the sensor for an extended time.
OBSCURATION mA output	Verify optical path is not obscured or perform the cleaning procedure below.
Elevated gas reading when no gas is expected to be present	Clean the optical window and mirror using the cleaning procedure below. Apply zero gas to see if reading drops to zero. If it does not, then perform Zero and Span calibration.
Unstable 4 mA signal after power on and warm up	Verify input voltage is between 20 - 30 VDC. If input voltage is within specification, check for noise on the input power cabling.
mA output current does not change when gas is applied	Verify that gas flow path is unobstructed. Visually inspect the gas inlets and the regulator. Verify that you are not in calibration mode or any of the defined mA output levels shown in chapter 5.1 Remote Controller and Menu Sequence . Verify that the device is not in Fixed Current Mode (Commanded via HART).
Calibration cap span fails	Pull the cap off and evacuate gas from the calibration cap. Retry the calibration procedure and verify the Zero calibration was successful. If Zero calibration returns "✓" and the Span calibration

Indication	Action
	fail, verify adequate span gas and flow. Verify that the Span gas is applied within the 30 second window. Check the o-ring integrity to ensure a good seal between the sensor and the calibration cap. Check the cap for damage.
Calibration cap rapidly flashes all icons during start-up	The calibration cap battery is nearing the end of its useful life. The calibration cap will continue to operate until the battery is consumed.
Known gas concentration response is incorrect	Calibrate. If calibration fails, remove power and reapply. Verify span gas flow rate and cylinder accuracy. Verify environmental guard and/or flow cap are not obstructed. Verify line load is according to electrical installation chapter 3.2 Electrical Installation . Verify ambient temperature range is appropriate for the device rating.
One source not flashing	The PrimaX IR+ is designed to meet all specifications with only one source. Source status is available through HART communication. See HART manual for details. Perform standard calibration. No further action required.

6.3 HART Information for Troubleshooting

The HART digital signal can provide additional information on the unit's health and status. Some of the information includes specific fault, calibration and obscuration status.

See the PrimaX IR HART specification document (10125187), which can be found on the product page <https://msasafety.info/PrimaXIRPlus>, for more information. Use the HART digital interface to query the unit to provide additional troubleshooting information.

6.4 Cleaning

The presence of particulate matter, oil films, liquid water, or the residue from water drops on the device optics can adversely affect its performance. The environmental guard is designed to prevent solids or liquids from reaching the monitor's optical system. Heating elements are also incorporated into the unit to prevent water condensation. Under severe conditions, however, some material may collect on these surfaces and it may be necessary to occasionally check and clean the windows.

Figure 21 Remove Environmental Guard

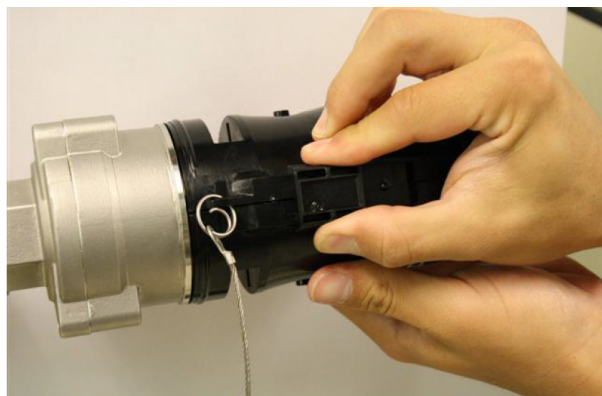

1. Remove the environmental or flow cap.

Figure 22 Light Path Obscuration



2. Place an opaque object (piece of paper, two fingers, etc.) between the light source window and the mirror to completely obscure the light path for two to three seconds (→ [Figure 22](#)).
 - If the opaque object is left in the light path for longer than 10 seconds, an Obscuration fault will be set on the mA output (→ [5.1 Remote Controller and Menu Sequence](#)).
 - The device enters the Cleaning Mode for 5 minutes.

⚠ WARNING!

The sensor will not respond to the presence of gas in cleaning mode.

Ensure that the environment is free of combustible gases before starting the cleaning procedure.

Failure to follow this warning can result in serious personal injury or death.

- The analogue current output will be set to the Cleaning Mode value (→ [5.1 Remote Controller and Menu Sequence](#)) during this time.
- If monitoring the HART signal, the Cleaning Status bit will be set.

Although both windows are made of a highly durable material that is not easily scratched, avoid excessive pressure when cleaning them. Clean, cotton tipped applicators are recommended to remove material collected on the windows.

3. Use a dry applicator or one moistened with distilled water to wipe the window and remove dust.
4. Use an additional clean, dry applicator to remove any residual water.
5. Use an applicator moistened with isopropyl alcohol to remove heavy deposits of solids, liquids or oil films. Clean the window again with a second applicator moistened with distilled water; then, dry the window with a final applicator.
6. Avoid using excessive amounts of water or alcohol in the cleaning procedure, and inspect the window to ensure that the entire surface is clean.

NOTE: When the cleaning process is complete, be sure to remove all objects from the light path.

When exiting the Cleaning Mode, the unit returns to normal operation. Note that residual cleaning fluids may result in an elevated signal until completely dry.

7. Inspect the environmental guard for any blockages, then replace the environmental guard on sensor.
 - After cleaning the windows, it is advisable to check the sensor's response to both zero and calibration gas.

NOTE: If water or isopropyl alcohol is used to clean the sensor's windows, any residue from the cleaning procedure must be completely dissipated before returning the unit to service. Checking the sensor's response to zero gas is the best way to purge residual cleaning materials from the sensor. Ensure that the sensor's reading is stable before zeroing or calibrating the sensor (→ [5.2 PrimaX IR+ Calibration](#)). Failure to do so could result in inaccurate readings.

⚠ WARNING!

Do not place foreign objects in the sensor's analytical region (except per the Cleaning Procedure above); otherwise, the infrared beam can be partially blocked, causing the sensor to generate false readings. All objects must be removed from the sensor's analytical region for it to function properly.

Failure to follow this warning can result in serious personal injury or death.

6.5 Calibration Cap Cleaning Procedure

In general, the calibration cap should not require any maintenance. However, if it is used in extremely dirty or solvent based environments, it may be necessary to clean the light sensor if the calibration cap performance is not adequate.

- Use a clean, dry applicator and isopropyl alcohol to gently swab the light sensor (→ [Figure 23](#)).

NOTICE

Never immerse the calibration cap in water or damage will occur.

Figure 23 Calibration Cap Diode Cleaning



7 Technical Data

Measuring Range		:	0 - 100% LEL
Power Input		:	24 VDC ± 20% PELV/SELV
Power Consumption		:	< 6.0 W
Signal Output	4 - 20 (safety function) three relay output (safety function)	:	3-wire current source One is fault relay; two gas alarm relay (0.5 A at 30 VAC)
Temperature Range	Detector	:	-40 to +75 °C
Temperature Range	Calibration Cap	:	-30 to +60 °C
Drift	Zero Drift	:	< 1% LEL/ 3 months
Drift	Gain Drift	:	< 2% LEL/ 3 months
Response Time	t50 with Environmental Guard	:	< 7 sec
Response Time	t90 with Environmental Guard	:	< 15 sec
Noise		:	< 1% FS
Humidity		:	15 to 95% RH, non-condensing
Sensor Life		:	(→ 1.4 MSA Permanent Instrument Warranty)
In-Rush Current		:	< 350 mA
Physical Characteristics	Length	:	320 mm
Physical Characteristics	Weight	:	2.5 kg (Aluminum) 3.5 kg (316 SS)
Physical Characteristics	Material Type	:	Aluminum and 316 Stainless Steel
Pressure		:	600 - 900 mmHg (80 - 120 kPa)
Ingress Protection		:	IP66/ IP67

8 Ordering Information

Description	Part No.
PrimaX IR+, SST, No Sensor	10242977
PrimaX IR+, Aluminum, No Sensor	10242978
PrimaX IR+, SST, Methane, 4.4%	10217785
PrimaX IR+, SST, Methane, 5.0%	10217786
PrimaX IR+, SST, Propane, 1.7%	10220542
PrimaX IR+, SST, Propane, 2.1%	10220543
PrimaX IR+, Aluminum, Methane, 4.4%	10220544
PrimaX IR+, Aluminum, Methane, 5.0%	10220545
PrimaX IR+, Aluminum, Propane, 1.7%	10220546
PrimaX IR+, Aluminum, Propane, 2.1%	10220547

8.1 Spare Parts

Description	Part No.
Electronics Module Assembly	10246257
Connector Terminal Plug Kit	10246258
Sensor O-ring	10105967

8.2 Accessories

Description	Part No.	Section
Calibration Cap	10111874	→ Figure 2
Insect Screen/ Remote Calibration Inserts	10116419	→ Chapter 8.7 Insect Guard Remote Calibration Inserts
Sun Shield	10113481	→ Chapter 8.4 Sunshield
HART Calibration Cover/Bump Cap	10122228	→ Figure 14
HART Hand-held Communicator Cable	10081441	→ Figure 20
Flow Cap	10113100	→ Chapter 8.3 Flowcap
3-way Pushbutton Valve	635729	→ Chapter 8.3 Flowcap
Environmental Guard	10113663	→ Figure 2
Duct Mount Flange	10114373	→ Chapter 8.5 Duct Mount Flange
Aluminum Junction Box Kit M25 (includes mounting bracket)	10117606	
316 SS Junction Box Kit M25 (includes mounting bracket)	10117609	
PrimaX IR, HART Remote Calibration, Kit	10122783	→ Chapter 8.7 Insect Guard Remote Calibration Inserts
PrimaX IR, Aluminum Junction Box, M25, "E", Kit	10117606	
PrimaX IR, Aluminum Junction Box, NPT, "D", Kit	10117607	
PrimaX IR, Stainless Junction Box, NPT, Kit	10117608	
PrimaX IR, Stainless Junction Box, M25, Kit	10117609	
J-Box, X Series, HART, Stainless Steel, NPT	10246266	

8 Ordering Information

Description	Part No.	Section
J-Box, X Series, HART, Stainless Steel, M25	10246267	
IR-Control device (Battery not included)	10180277-SP	
Panasonic CR2025 Lithium Battery	10246473	
PrimaX IR, Environmental Guard SS Tether	10114097	
Adapter, M25 to 3/4 NPT	10179524	
Cal Gas flow regulator (1.5 LPM)	467896	

8.3 Flowcap

Figure 24 Flow Cap



The flow cap is for use with a sampling system. It is available in 316 stainless steel and is secured to the sensor in place of the environmental guard with two screws.

A 3-way pushbutton valve is available for ease of calibration when using the flow cap. The sample flow and the calibration gas can both be plumbed to this valve, and the operator holds down the pushbutton to switch the flow to the calibration gas.

NOTE: Using the flow through adapter can extend the response time, depending on the gas flow rate and system design.

8.4 Sunshield

The sun shield is a 316 stainless steel plate that protects the sensor from direct sunlight and from excessive temperature rise.

Figure 25 Sun Shield



8.5 Duct Mount Flange

Gas monitoring in air ducts can be performed by means of this duct mount flange. A remote sensor kit is required for duct mounting.

Install the sensor in a location that is convenient for maintenance, where it will be exposed to a representative sample and is not subject to extremes of flow, turbulence, temperature and particulate.

When installing, the direction of flow inside the duct must be as shown below (→ [Figure 26](#)).

Calibration of the device mounted in an air duct must be done with the HART interface. Once calibration has been initiated, apply the calibration gasses via the gas calibration port. Ensure that the duct is free of all gases to which the sensor will respond and the duct flow rate is below 1 m/s. If hydrocarbon combustible gas is present in the duct, the sensor must be removed from the duct during calibration. The sensor can be removed from the duct mount bracket via four screws.

Figure 26 Duct Mount

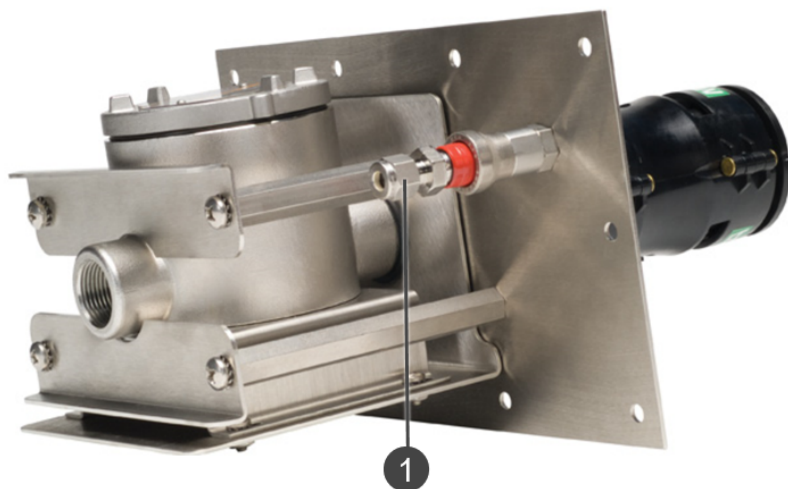

1 Gas calibration port

8.6 HART Module

The HART Module is a 316 Stainless Steel enclosure that provides a hazardous area approved HART port for access to the HART signal. The PrimaX IR+ can be mounted to this module using an available port and all applicable facility wiring rules from Section apply to wiring the HART Module.

Figure 27 HART Module



An optional cable is available from MSA to connect to the XP HART port from a hand-held controller.

8.7 Insect Guard Remote Calibration Inserts

For applications where HART is being used for calibration and the sensor is located in a remote location where use of the calibration cover is not practical, optional screen inserts are available. These inserts snap into the environmental guard (→ [Figure 28](#)) and permit a very slow diffusion of gas through the tight mesh screens. This allows enough zero and span gas to be retained in the environmental guard for the calibration procedure to be accurate for still air applications.

⚠ WARNING!

Use of these inserts will increase the sensor response time to ambient gas conditions. Ensure that the conditions are appropriate for use of these screens.

Failure to follow this warning can result in serious personal injury or death.

These screens can be used as an insect guard.

Figure 28 Remote Cal/ Insect Screen Inserts



For remote calibrations the HART Remote Calibration Kit is also recommended (P/N 10122783).

Figure 29 Remote HART Calibration Kit



9 General Certification Information

Refer to manual addendum (10217781) for additional certification information.