



PRODUCT INFORMATION

Model 120R, 122R and 125R—MOUDI II™ Impactors

- *Second generation Micro-Orifice Uniform-Deposit Impactor (MOUDI II™)*
- *Internal stepper-motor stage rotation provides uniform particle deposition on collection substrates*
- *Precision, high accuracy, wide-range aerosol sampling from 10 nm to 10,000 nm with 13 impaction stages*



Model 120R
30 L/min 10 Stage
MOUDI II impactor



Model 125R
10 L/min 13 Stage
MOUDI II impactor

INTRODUCTION

MOUDI II™ impactors are second generation MOUDI™ impactors. Both the MOUDI II and the original MOUDI impactors are precision cascade impactors for high-accuracy aerosol sampling that collects size-fractionated particle samples for gravimetric and/or chemical analysis. The primary difference between MOUDI and MOUDI II impactors is the use of internal embedded stepper motors. The MOUDI II impactor spreads out the particle deposit to achieve a nearly uniform deposition on the collection substrate, while the original MOUDI impactors used external mechanical gear rotation to achieve the uniform particle deposition.

Both impactors use micro-orifice nozzles to reduce jet velocity, pressure drop, particle bounce, re-entrainment, and evaporative loss. The Model 122R Nano-MOUDI Impactor has up to 6,000 micro-orifice nozzles as small as 50 µm in diameter.

The original MOUDI impactors are noted for their superior aerodynamic design, sharp cut-size characteristics, and low inter-stage particle losses. These valuable features combined with their accurate cut-size calibration, have made the MOUDI and MOUDI II impactors the impactor of choice for high quality aerosol and environmental research.

Both models 122R and 125R MOUDI II impactors have 13 impactor stages. The Model 122R operates at a 30 L/min sampling flow rate, while the Model 125R operates at 10 L/min. Both Model 122R and 125R have a final stage cutpoint of 10 nm. In addition, a 10-stage version of the 30 L/min MOUDI II (120R) is available for sampling to a smallest cutpoint of 56 nm.

Model 122R Nano-MOUDI II impactor has internal embedded stepper motors for the rotation of the impaction plates (in the upper ten stages), while the last 3 stages are non-rotating.

Models 120R, 122R and 125R have electronic control for stage rotation, and built-in sensors that continuously monitor the instrument temperature and pressures during sampling. Absolute pressure sensors monitor the pressure in the micro-orifice stages and the stability of flow. Should the micro-orifice nozzles of a stage become partially clogged during sampling, change in stage pressure drop will be quickly noted. Built-in electronics oversees the entire instrument operation and records temperature and pressure data generated for post-sampling review. Instrument can be controlled remotely through an Ethernet port.

DESCRIPTION

All MOUDI II impactors have the same aerodynamic design as in the original MOUDI impactors that have led to sharp cut characteristics (see Figure 3) and low inter-stage wall losses.

The rotating versions of the MOUDI II impactors are 2nd generation MOUDI impactors using individual stepper motors embedded in each stage to rotate the collecting substrate for uniform deposition. Power for the stepper motors comes from a single electronic package in the instrument cabinet, with power distributed to the individual motors by miniature flat-ribbon cables. Figure 1 shows a typical rotating stage, and Figure 2 shows a photograph of the stage with the uniform particle deposition on the center circular area.

The Models 120R, 122R and 125R are provided with instrument cabinets that also house the electronics for controlling the pump operation, monitoring and recording the output of the six pressure transducers. These features ensure the high quality of samples collected by the user.

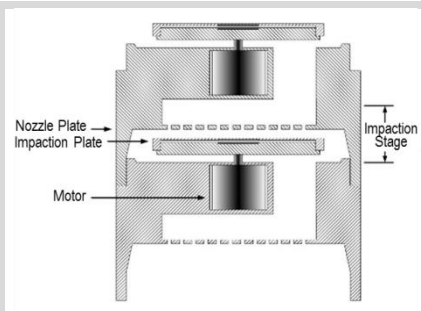

Figure 1. Typical stepper motor operated impactation stage



Figure 2. Typical stage with uniform deposit

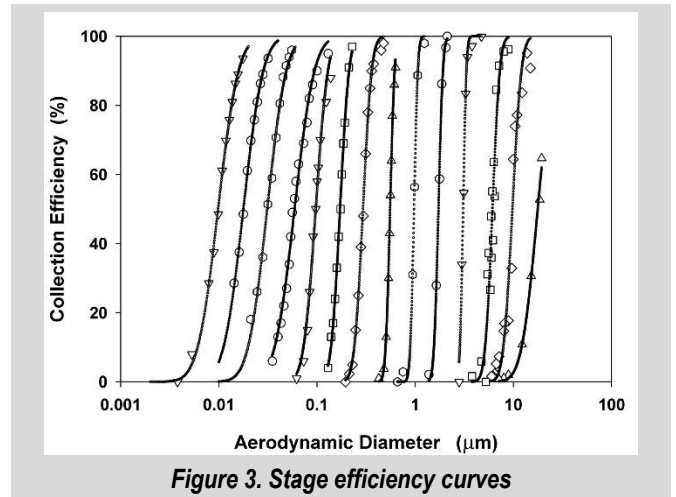

Figure 3. Stage efficiency curves

FEATURES

- Sampling flow rate:
 - Models 120R and 122R: 30 L/min
 - Model 125R: 10 L/min
- Size intervals and stage cut-sizes
 - Four equal geometrical increments per decade of particle size
 - Model 120R: 0.056, 0.10, 0.18, 0.32, 0.56, 1.0, 1.8, 3.2, 5.6 and 10 μm , plus 18 μm inlet
 - Model 122R: 0.010, 0.018, 0.032, 0.056, 0.10, 0.18, 0.32, 0.56, 1.0, 1.8, 3.2, 5.6, and 10 μm , plus 18 μm inlet
 - Model 125R: 0.01, 0.018, 0.032, 0.056, 0.10, 0.18, 0.32, 0.56, 1.0, 1.8, 3.2, 5.6 and 10 μm
- Easily removable collection substrates allow for quick turn-around time for productive use of the instrument.
- Programmable logic controller (PLC) controls instrument operation including start and stop times. Instrument temperature and pressures are measured, recorded, and stored at pre-determined time intervals.
- Pump Control
- Remote operation capability via Ethernet
- Sharp cut-off size characteristics
- Low inter-stage losses
- Up to 6000 micro-orifice nozzles to reduce jet velocity, pressure drop, particle bounce and re-entrainment.

APPLICATIONS

- Sampling of atmospheric aerosols for research and environmental monitoring
- Workplace aerosol analysis
- Diesel emissions analysis and monitoring
- Exposure monitoring
- Industrial hygiene studies

TO ORDER

MOUDI II Impactors:

Specify	Description
120R	MOUDI II Impactor, 10 Stage
122R	Nano-MOUDI II Impactor, 13 Stage
125R	Nano-MOUDI II Impactor, 13 Stage

Accessories:

Specify	Description
0120-98-1051	Vacuum Pump, 120R, 110V
0120-98-1050	Vacuum Pump, 120R, 220V
0122-01-2016	Vacuum Pump, 122R, 230V, EU
0122-01-2011	Vacuum Pump, 122R, 230V, US
0125-98-0100	Vacuum Pump, 125R, 110V
0125-98-0101	Vacuum Pump, 125R, 220V
0100-96-0573	Al Foil Substrates, 47mm, Pkg. 300
0122-96-5222	Al Foil Substrates, 90mm, Pkg. 100
0001-01-9953	Glass Fiber Filters, 47mm, Pkg. 100
0001-01-5024	Quartz Fiber Filters, 47mm, Pkg. 100
0130-01-5010	Glass Fiber Filters, 90mm, Pkg. 100
0100-01-0100	Silicone Impactor Surface Spray
0100-96-0558	Silicone Lubricating Grease, 5.3 oz.

SPECIFICATIONS*

*Specifications are subject to change without notice

	Model 120R (with internal rotation)	Model 122-R (with internal rotation)	Model 125-R (with internal rotation)
Impactor Stages	10	13	13
Flow rate, L/min	30	30	10
Pressure Drop, kPa (w/o final filter)	41	90	90
Cut-point diameter, µm	0.056, 0.10, 0.18, 0.32, 0.56, 1.0, 1.8, 3.2, 5.6, 10, 18	0.01, 0.018, 0.032, 0.056, 0.10, 0.18, 0.32, 0.56, 1.0, 1.8, 3.2, 5.6, 10, 18	0.01, 0.018, 0.032, 0.056, 0.10, 0.18, 0.32, 0.56, 1.0, 1.8, 3.2, 5.6, 10
Dimensions (D x H) or (W x L x H)	80 x 510 mm (impactor) 210 x 640 mm (cabinet)	130 x 640mm (impactor) 235 x 190 x 205 mm (cabinet)	80 x 510 mm (impactor) 210 x 640 mm (cabinet)
Weight (total)	19 kg (42 lb.)	11 kg (24 lb.)	14 kg (31 lb.)
Power (cabinet)	100–240 VAC, 50–60 Hz, 30 W	100–240 VAC, 50–60 Hz, 30 W	100–240 VAC, 50–60 Hz, 30 W
Vacuum Pump	Carbon Vane, 115 or 230 VAC, 50–60Hz, 0.56 kW	Oil Pump, 230VAC only, 50–60 Hz, 1.5 kW	Oil Pump, 115 or 230VAC, 50–60 Hz, 0.9 kW

Environmental Operating Conditions:
(impactor and cabinet)

T: 10–50°C (50–122°F)
RH: 10%–90% RH (non-condensing)

MSP Corporation

5910 Rice Creek Parkway, Suite 300
Shoreview, Minnesota 55126, U. S. A.
Phone: 651.287.8100; Fax: 651.287.8140
sales@mspcorp.com; www.mspcorp.com

Copyright© 2017 MSP Corporation (MSP-PI-120 Rev. C – A4). All rights reserved.

The MSP logo is a registered trademark and MOUDI is a trademark of MSP Corporation.
TSI and the TSI logo are registered trademarks of TSI Incorporated.

Patents: US7082811, EP1660863, JP4519842, DE602004025008