



TRG802X

GUIDED WAVE RADAR LEVEL TRANSMITTER

Operating Manual

TRG802X-DT-JS-1005-2018(A)



PREFACE

Thank you for choosing the products of Dandong Top Electronics Instrument (Group)-Co.,Ltd. This operation manual provides you with important information on installation, connection and commissioning as well as on maintenance, troubleshooting and storage.

Please read it carefully before installation and commissioning and keep it as part of the product near the meter for easy reading.

This manual can be downloaded by entering the version number at www.ddtop.com.

If the instructions are not followed, the protection provided by the meter may be destroyed.

Trademark, Copyright and Restriction Instructions

Dandong Top Electronics Instrument (Group) Co.,Ltd.®, Dandong Top Pump Co.,Ltd.®, DDTOP® are registered trademarks of the company.

The performance specifications of the meter are effective as of the date of publication and are subject to change without notice. Dandong Top Electronics Instrument (Group)Co.,Ltd. reserves the right to modify the products described in this manual at any time without prior notice.

Quality Assurance

Dandong Top Electronics Instrument (Group) Co.,Ltd. guarantees that all variable area flow meters have no defects in materials and manufacturing processes within one year from the date of delivery. During the warranty period, if the product returns with quality problems and the claim is determined by the manufacturer to be within the scope of warranty, Dandong Top Electronics Instrument (Group) Co.,Ltd. is responsible for repair or replacement of the buyer (or owner) free of charge. Dandong Top Electronics Instrument (Group) Co.,Ltd. is not responsible for the costs caused by improper use of equipment, labor claims, direct or subsequent damage and installation and use of equipment. In addition to the special written warranty certificate for certain products of Dandong Top Electronics Instrument (Group) Co.,Ltd., Dandong Top Electronics Instrument (Group) Co.,Ltd. does not provide any express or implied warranty.

Quality

Dandong Top Electronics Instrument (Group) Co.,Ltd. has passed the ISO9001 quality system

certification. The whole process of product production is strictly in accordance with the scope of the quality system, providing the strongest guarantee for product and service quality.

Content

1. Safety Tips	5
2. Product Descriptions	5
3. Technical Parameters	6
4. Outline Dimension Diagram	9
5. Unpacking and Inspection	12
6. Installation	13
7. Instrument Configuration.....	14
8. Precautions	25
9. Fault Analysis and Troubleshooting	25
10. Disassemble	26
11. Product Certification	26

1. Safety Tips

For safety reasons, it is expressly prohibited to modify or change the product without authorization. Repair or replacement is only allowed to use the accessories specified by the manufacturer.

1.1 The explosion may cause death or serious injury.

When installing the device in an explosive environment, be sure to comply with applicable local, national and international standards, codes and regulations. Ensure that the equipment is installed in accordance with intrinsically safe or non-flammable site operating procedures.

1.2 Process leakage may cause serious injury or death.

If the process seal is damaged, the medium may leak at the connection.

1.3 Failure to follow the safety installation guidelines may result in death or serious injury.

All operations described in this manual must be carried out by trained and qualified or end-user-appointed personnel.

2. Product Descriptions

2.1 Main structure-Figure 1

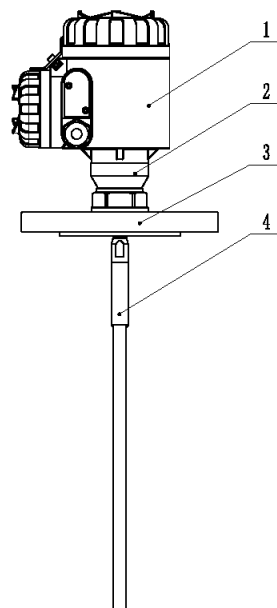

Figure 1 Product Main Structure

1. Transmitter, with circuit board module inside

2. Sealing component, with sealing structure inside
3. Flange, with flange installation on site
4. Measuring rod (cable), selected according to site conditions

2.2 Working Principle

Guided wave radar emits microwave pulses with very low energy. The pulse propagates along the measuring rod (cable) at the speed of light and encounters the surface of the measured medium. Part of its energy is reflected back and received by the measuring module. The time interval between the transmitted pulse and the received pulse is proportional to the distance from the antenna to the surface of the measured medium. In order to calculate the distance from the antenna to the surface of the measured medium.

2.3 Packaging

Please send packaging waste to a special recycling agency.

2.4 Lifting and Transportation

Please use quality lifting equipment and lifting straps, and pay attention to safety.

2.5 Storage

Storage temperature $-20^{\circ}\text{C}\sim 40^{\circ}\text{C}$

Storage humidity $\leq 40\%$

3. Technical Parameters

3.1 Key Performance

Power Supply: (16 ~ 36) V DC (two-wire)

Output Signal: 4 ~ 20mA

Structure Type: Coaxial type, double rods, single rod, double cables, single cable

Two-wire load resistance diagram 2

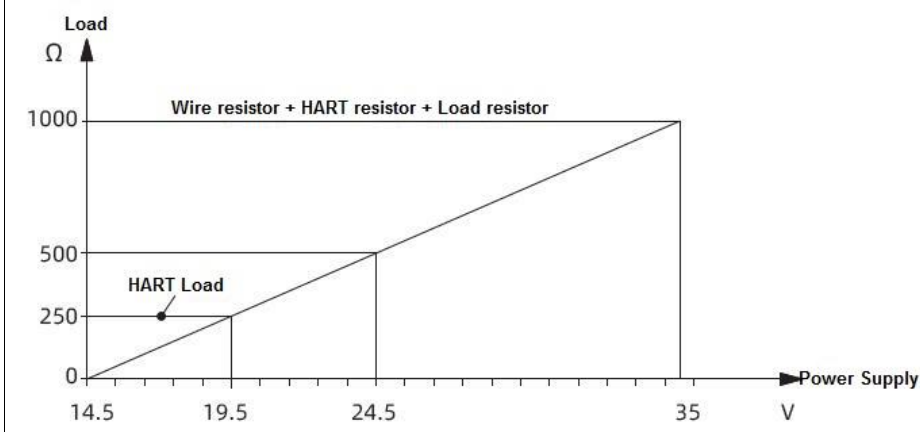

Figure 2 Two-wire Load Resistance Diagram

3.2 Appearance and Performance Parameters

TRG8021-Apperance

TRG8021-Performance parameter



Antenna structure: coaxial

Application conditions: small dielectric constant,
low viscosity liquid

Measuring range: 6m

Measurement accuracy: $\pm 10\text{mm}$

Process temperature: $(-40 \sim 250)^\circ\text{C}$

Process pressure: $(-0.1 \sim 4.0) \text{MPa}$

TRG8022- Apperance

TRG8022- Performance parameter



Antenna structure: double rods

Application conditions: small dielectric constant liquid, solid

Measuring range: 6m

Measurement accuracy: $\pm 10\text{mm}$

Process temperature: $(-40 \sim 250)^\circ\text{C}$

Process pressure: $(-0.1 \sim 4.0) \text{MPa}$

TRG8023- Appearance



TRG8023- Performance parameter

Antenna structure: single rod

Application conditions: large dielectric constant liquid, solid

Measuring range: 6m

Measurement accuracy: $\pm 10\text{mm}$

Process temperature: $(-40 \sim 250)^{\circ}\text{C}$

Process pressure: $(-0.1 \sim 4.0)\text{MPa}$

TRG8024- Appearance



TRG8024- Performance parameter

Antenna structure: double cable

Application conditions: large range and small dielectric constant liquid, solid

Measuring range: 30m

Measurement accuracy: $\pm 10\text{mm}$ or $0.1\%\text{FS}$ (whichever is greater)

Process temperature: $(-40 \sim 150)^{\circ}\text{C}$

Process pressure: $(-0.1 \sim 4.0)\text{MPa}$

TRG8025- Appearance



TRG8025- Performance parameter

Antenna structure: single cable

Application conditions: large range and large dielectric constant liquid, solid

Measuring range: 30m

Measurement accuracy: $\pm 10\text{mm}$ or $0.1\%\text{FS}$ (whichever is greater)

Process temperature: $(-40 \sim 250)^{\circ}\text{C}$

Process pressure: $(-0.1 \sim 4.0)\text{MPa}$

3.3 Explosion-proof Mark

Passed the national explosion-proof certification, certification mark:

Intrinsically safe Ex ia IIC T1 ~ T5/T6 Ga; Ex iaD 20 T85°C

Intrinsically safe and flameproof composite type Ex d ia [ia Ga]IIC T1 ~ T5/T6 Gb; Ex tD A21 T100°C /T85°C

3.4 Executive Standard

TRG802X radar level transmitter executive standard

JB/T 13252-2017_Microwave (radar) level transmitter;

4. Outline Dimension Diagram

If special size is required when ordering, the actual size shall prevail.

Figure 3-1 External dimensions of meter

Figure 3-2 TRG8021 Dimensions

Figure 3-3 TRG8022 Dimensions

Figure 3-4 TRG8023 Dimensions

Figure 3-5 TRG8024 Dimensions

Figure 3-6 TRG8025 Dimensions

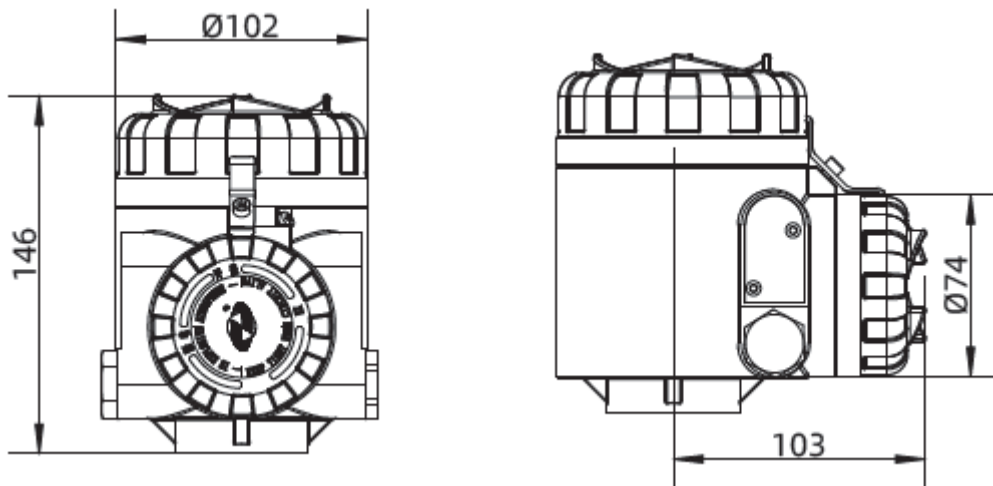

Figure 3-1 Overall Dimension of Transmitter

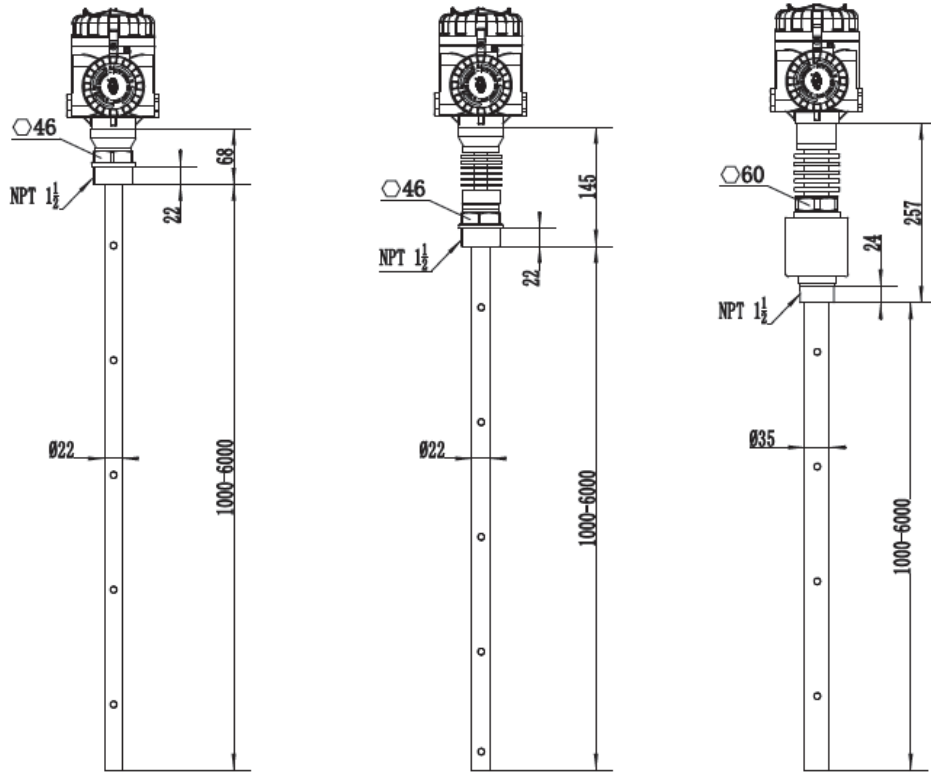

Figure 3-2 TRG8021 Dimension

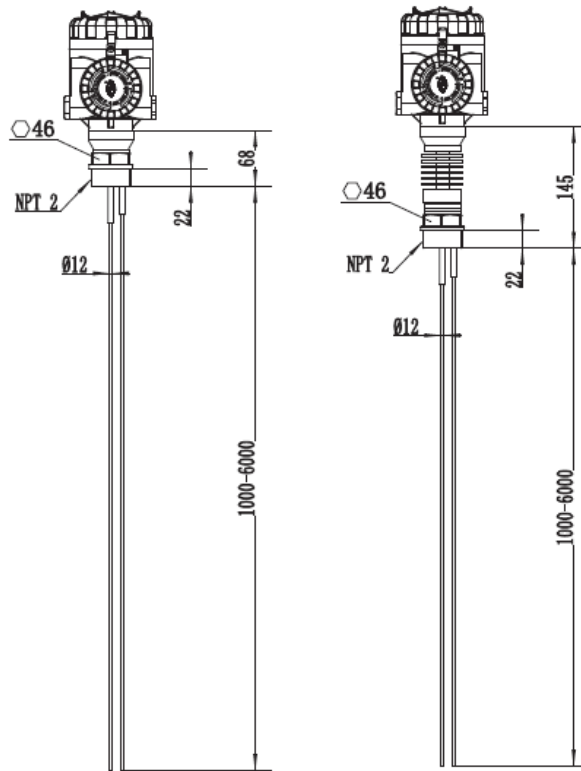

Figure 3-3 TRG8022 Dimension

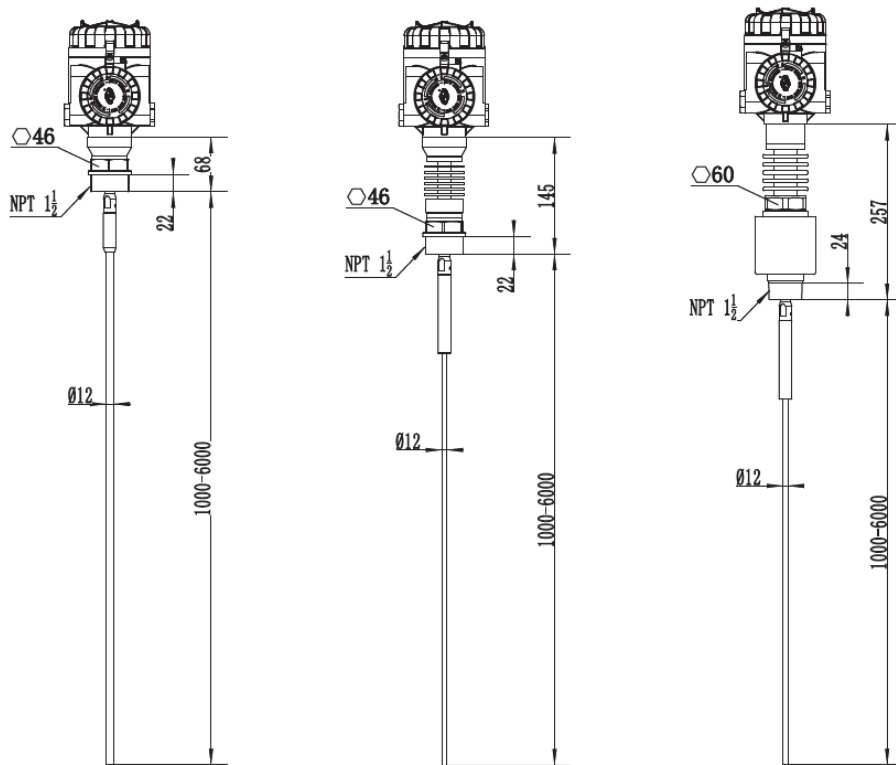

Figure 3-4 TRG8023 Dimension

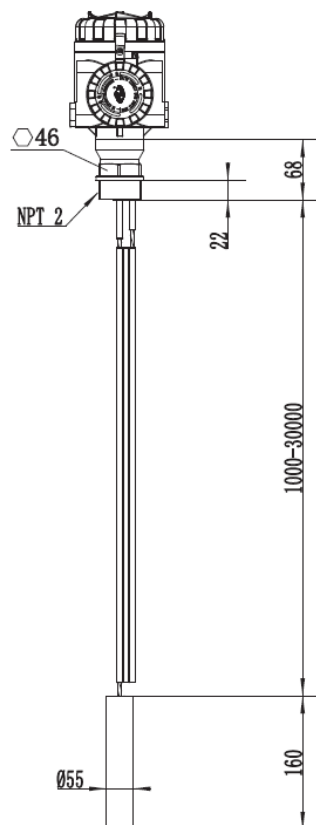

Figure 3-4 TRG8024 Dimension

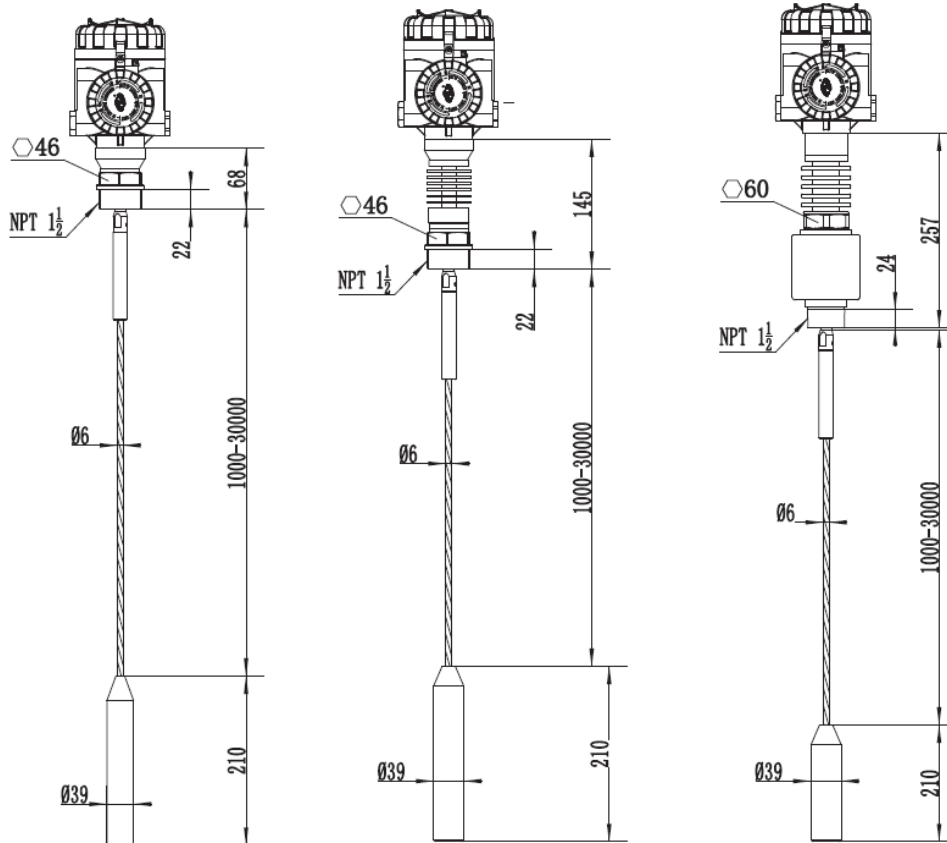

Figure 3-4 TRG8025 Dimension

5. Unpacking and Inspection

5.1 Precautions for Unpacking Inspection

5.1.1 Check whether the product nameplate (Figure 4) is consistent with the supply list information

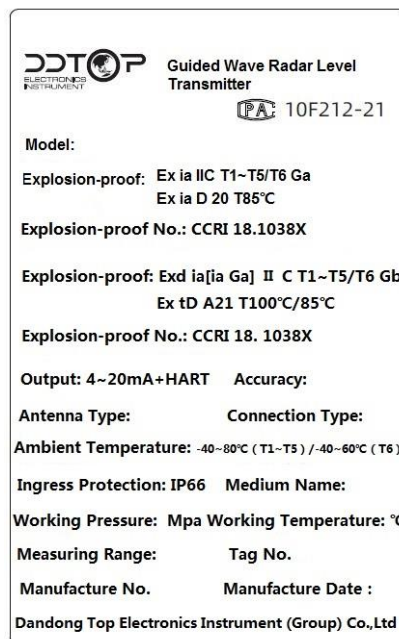

Figure 4 Product Nameplate

5.1.2 Check the quantity and material of each part against the packing list.

5.2 Content of Inspection

5.2.1 Check whether the appearance of the meter is defective or damaged.

6. Installation

6.1 Installation Tool

Tools suitable for process connections like wrenches, flange gaskets and flange bolts.

6.2 Installation Technical Requirements

Installation Location

For a cone-shaped container with a flat tank top, the best installation position of the meter is the center of the top of the container, which can ensure the bottom of the measuring container, as shown in Figure 5.

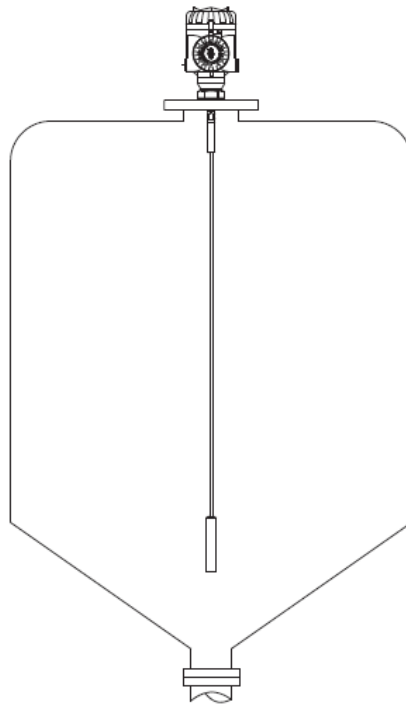

Figure 5 Diagram of Installation Position of Cone Bottom Tank

Moisture proof

For installation in an outdoor or humid room and on a cooling or heating tank, in order to prevent moisture, the cable gland should be tightened, and the cable should be bent downward at the inlet,

as shown in Figure 6.

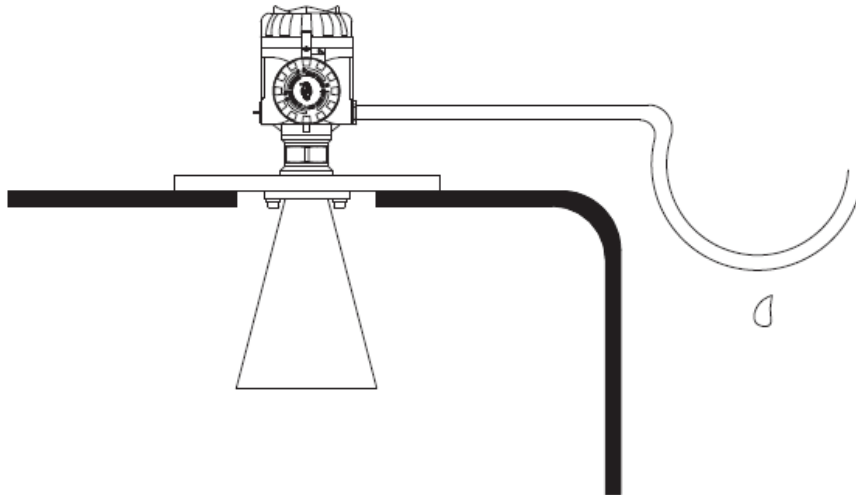

Figure 6 Diagram of Moisture-proof Wiring

Container Tube Connection

Try to avoid connecting pipe installation or connecting pipe as small as possible. When the connecting pipe is long, the medium container is small or the dielectric constant of the medium is small, the coaxial structure can be adopted, as shown in the schematic diagram of the container connecting pipe in Figure 7.

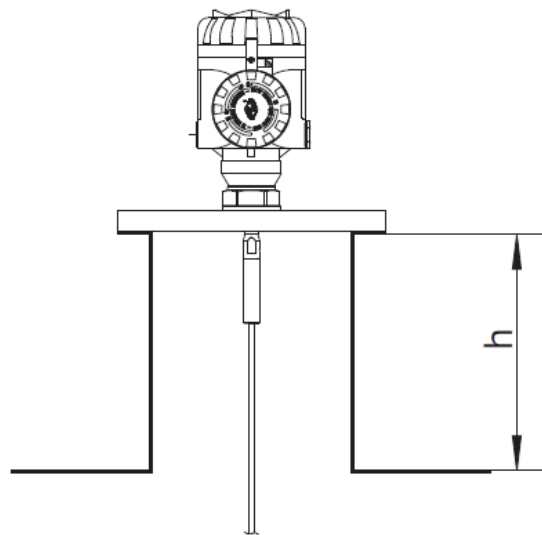

Figure 7 Diagram of Container Connecting Pipe Connection

7. Instrument Configuration

7.1 Electrical Wiring

According to the wiring shown in Figure 8 below, terminal 2 is connected to 24VDC positive and terminal 1 is connected to 24VDC negative.

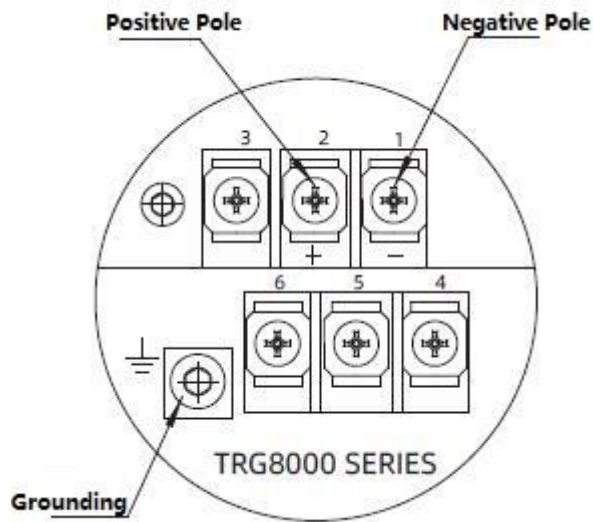

Figure 8 Electrical Wiring

7.2 Configuration Operation Process

7.2.1 Diagram of Parameter Setting-Figure 9

The reference surface of the measurement is the sealing surface of the thread or flange

- ① -Blind area;
- ② -Range setting;
- ③ -High adjustment;
- ④ -Low adjustment

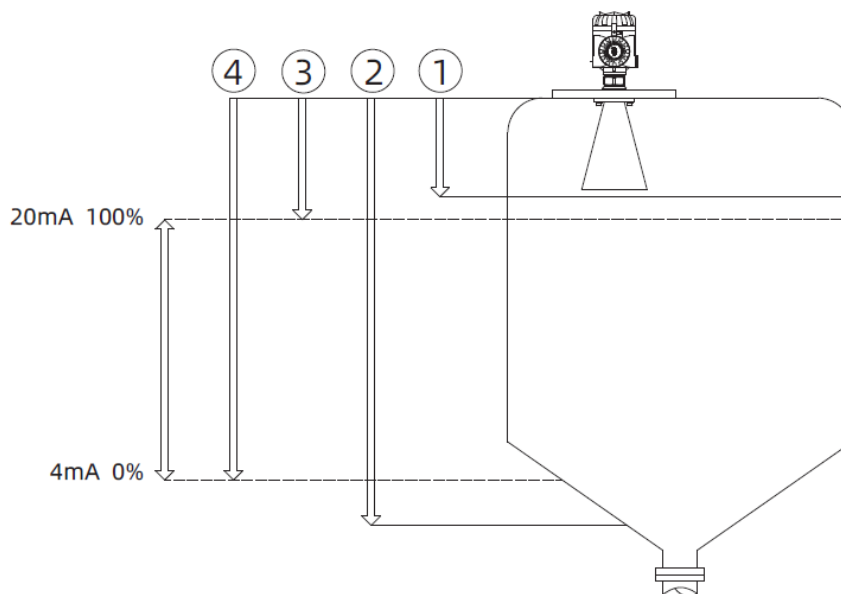

Figure 9 Diagram of Parameter Setting

7.2.2 Introduction to Operation Interface

There are 4 buttons on the instrument panel (Figure 10), and the instrument can be configured through the 4 buttons. The language of the configuration menu is optional. After configuration, the LCD screen displays the measured value, and the measured value can be read out very clearly through the glass window.

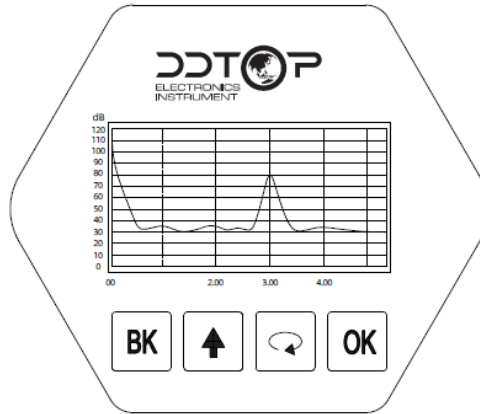

Figure 10 Instrument Panel

【BK】 key	【↑】 key	【↻】 key	【OK】 key
-Exit the programming state	-Modify parameter value	-Select programming items	-Enter programming state
-Back to the previous menu		-Select to edit parameter bits	-Confirm programming
-Display echo curve		-Parameter item content display	-Confirm parameter modification

Basic settings

The basic settings include the basic parameters of the instrument: low position adjustment, high position adjustment, material properties, damping time, signal threshold, cable length setting, selection of the first wave, small DK value, underlayer medium, DK value measurement, still-pipe measurement, current Output.

Display

Display and set the display mode of the meter: display content, LCD contrast, decimal places, measurement unit

Diagnose

Diagnosis completes the inspection and testing functions of the instrument. Mainly include: measuring peak value, measuring state, selection curve, echo curve and simulation.

Service

Including distance offset, learning password, false echo, learning range, 4mA calibration, 20mA calibration, tracking range, reset, copy sensor data, measurement range.

Information

Basic instrument information such as sensor tag, product model, serial number, production date, and software version.

Programming Method

When the instrument is running, press the OK key to enter the programming state and display the programming main menu. After editing each parameter, press OK to confirm, otherwise the editing is invalid. After finishing editing, press BK key to exit programming state and return to running state. At any time during programming, it is available to press BK key to abandon programming and exit the parameter item programming state.

7.2.3 Configuration Steps

Basic settings

Basic settings include the settings of main instrument parameters, such as range, material properties, damping time, etc. In the running state, press the OK key to enter the programming state, the LCD displays the main menu, as shown in Figure 11-1 Basic Settings

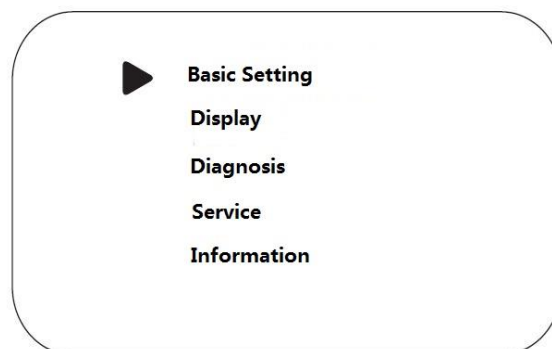

11-1 Basic Setting

Low adjustment

Low adjustment is used for range setting. Together with the high level adjustment, it determines the ratio of the current output linear corresponding relationship. In the main menu, when the menu number is 1, press the OK key to enter the basic setting sub-menu, LCD display, as shown in Figure 11-2 low adjustment.

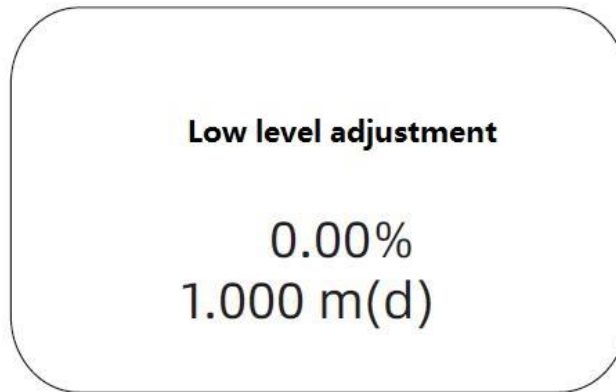

11-2 Low level adjustment

Press OK to enter the programming low percentage, refer to the character/number parameter programming method in the parameter editing method to edit the percentage value and distance value. After editing, press OK key to confirm, press BK key to abandon programming.

High adjustment

High level adjustment is used for range setting. It, together with the low level adjustment, determines the ratio of the current output linear corresponding relationship. When the menu number of the LCD display is 1.1, press the key  to enter the high position adjustment, and the LCD display is shown in Figure 11-3.

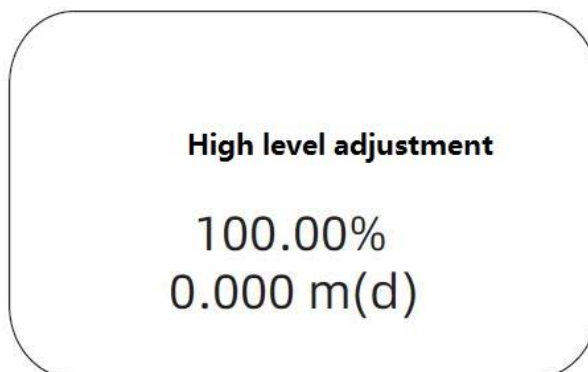



Figure 11-3 High Level Adjustment

At this point, press the OK key to edit the high adjustment.

Material Property

When the LCD menu number is 1.2, press the key  to enter the material properties programming, LCD display such as Figure 11-4 material properties. The material property menu is used to select solid or liquid, so as to further determine some other properties of the material that affect the measurement.

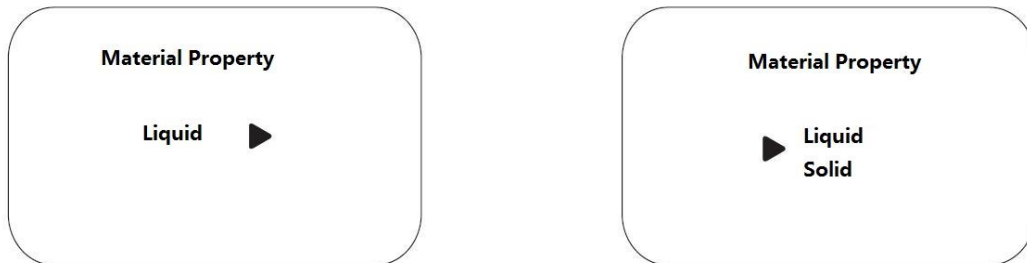



Figure 11-4 Material Property

Damping time

Basic Setup sub-menu press key to enter the Damping Time setting menu, LCD display, as shown in Figure 11-5 Damping Time.



11-5 Damping Time

Press OK to enter the parameter editing state, use the \uparrow key to set the number, use the key  to select the digit to be edited, and press OK to confirm when the editing is finished.

Cable length setting

In order to get the correct measurement result, you need to set the cable length of the instrument. Press the key to enter the cable length setting menu, as shown in figure11-6 Cable length setting.

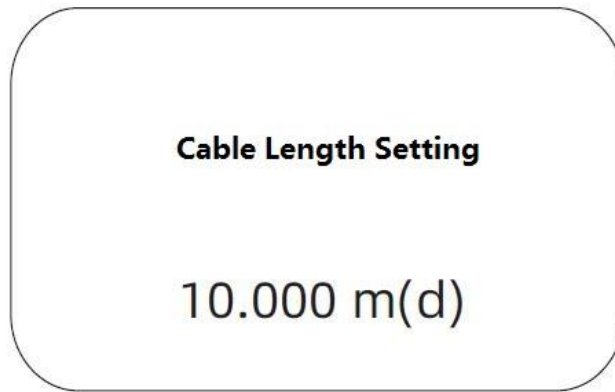

11-6 Measuring Range Setting

Press OK key, the corresponding parameter is blacked out, use ↑ or ↓ key to set the parameter, and press OK key to confirm.

Display

This function is used to program the display mode. When the LCD displays the main menu, press the key to move the arrow to the display item and the LCD is displayed, as shown in Figure 11-7, press OK to enter display mode programming.

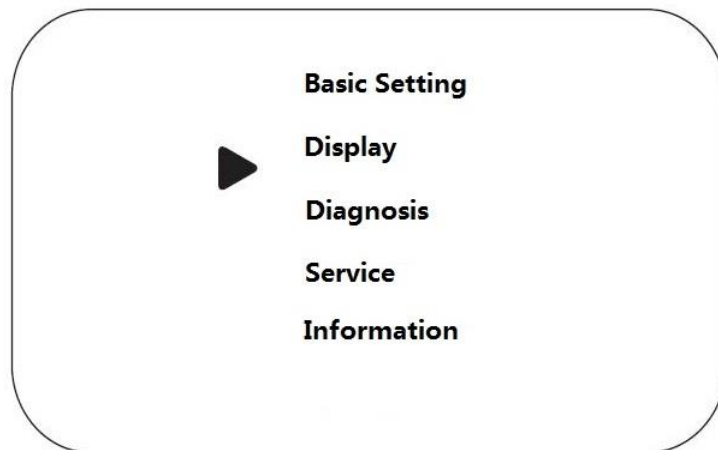

11-7 Display

Display content

Enter the display mode programming, LCD display, as shown in Figure 11-8.

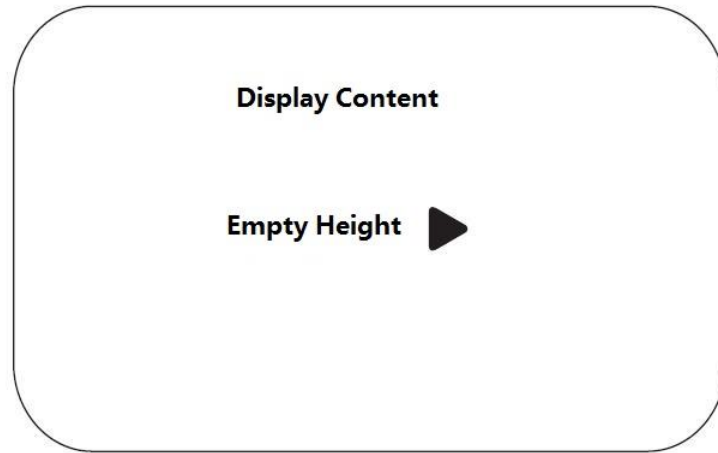

11-8 Enter Display

The parameter that indicates the current display is the empty height, i.e., the instrument displays the measured empty height value. Press OK key to enter the edit state, the LCD display, as shown in figure 11-9 shows the empty height.

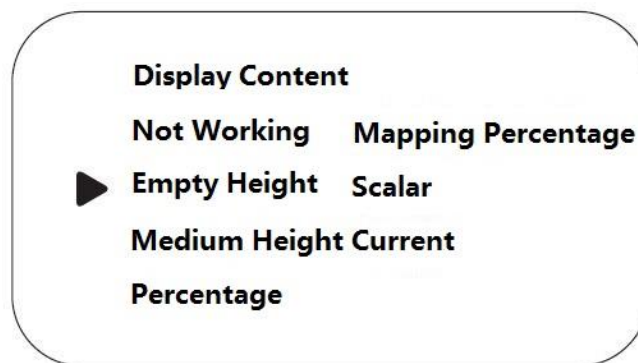

11-9 Display Empty Height

Use the key  to move the arrow to the desired parameter item and press OK to confirm.

When editing is complete, press the BK key to exit display programming and return to the previous menu.

Services

The service menu includes more specialized functions. The main ones are false echo learning, time-varying gain control, reset, and instrument parameter saving. When the LCD displays the main menu, press the key, move the arrow to the service item, and the LCD displays, as shown in Figure 11-10 Service.





11-10 Service

False Echo

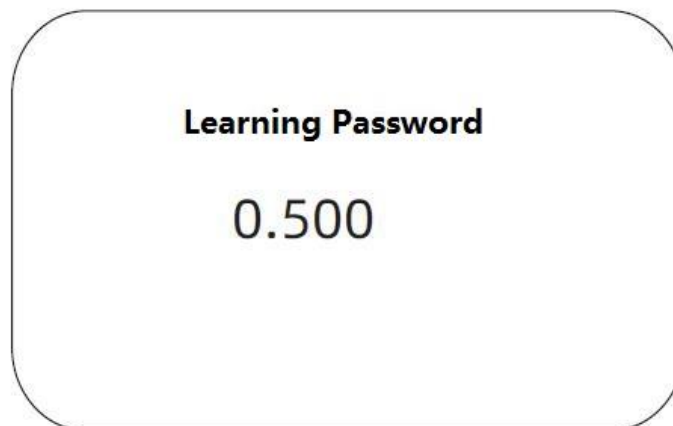
When there is a fixed obstacle in the measurement range that interferes with the measurement, the false echo learning function can be used to overcome its influence. Press the OK key in the service main menu to enter the service sub-menu, press the key  to find the learning password page, and the LCD displays learning password, as shown in Figure 11-11.



11-11 Learning Password

Press OK key to change the learning password, and change the password to 0.400 by pressing  and  key, and then press OK key briefly to confirm. Press the key to find the page of false echo and the LCD display, as shown in Figure 11-12 False Echo.



11-12 False Echo

Press OK to enter the False Echo sub-menu, LCD display, as shown in Figure 11-13 False Echo sub-menu.



11-13 False Echo Submenu

By pressing the key  to point the arrow to the new code option, press OK to enter the false echo learning, LCD display False Echo, as shown in Figure 11-14



11-14 False Echo

Press  and hold the key, if enter the false echo learning measurement, learning time of about 5

minutes, LCD display echo measurement as shown in 11-15 false.

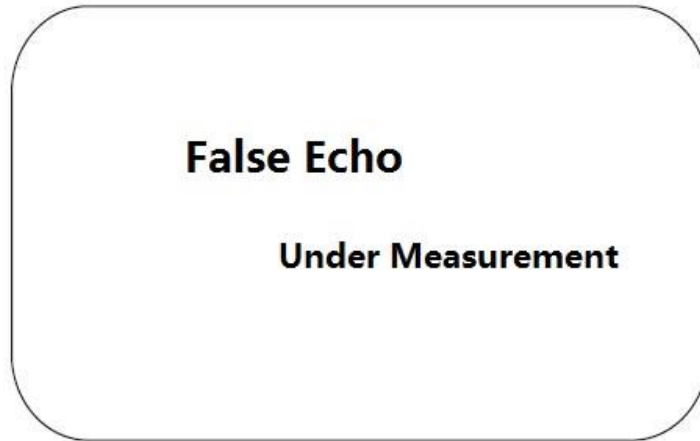

11-15 False Echo Measurement

When the learning is complete, the interface automatically jumps to the waveform display, LCD display waveform display as shown in Figure 11-16.

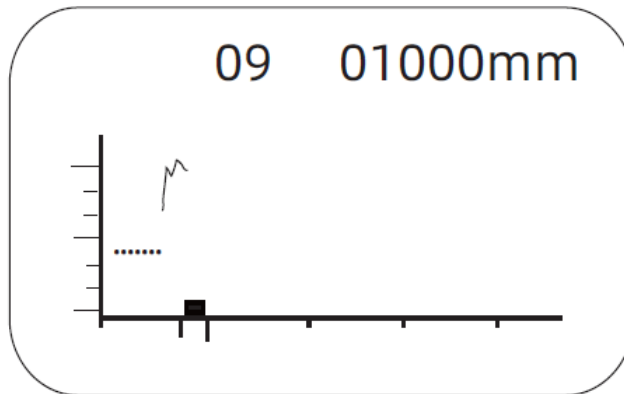

11-16 Waveform Display

At this point, you need to repeat the learning password setting procedure and change the learning password to 0.100.

Measuring range

Set the measuring range display. In the services sub-menu, press the key  to find the measurement range page, and the LCD displays the measurement range, as shown in Figure 11-17.

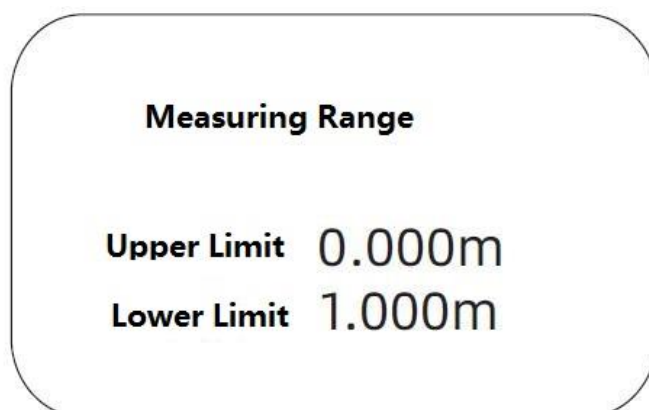

11-17 Measuring Range

Press OK to enter the parameter editing state, use the ↑ key to set the number, use the key  to select the digit to be edited, and press OK to confirm when the editing is finished.

8. Precautions

8.1 Make sure the power supply is safe and reliable. The power supply should be connected according to the correct positive and negative polarity, and ensure that the meter ground terminal is reliably grounded.

8.2 When installing a guided wave radar level meter, take care not to install it above the material flow. If this is unavoidable, it is recommended to install a waveguide or bypass tube to facilitate the measurement.

8.3 During installation, ensure that the radar antenna is perpendicular to the surface of the medium to be measured, connect the radar to the tank flange, and use tools to tighten the fixing screws.

8.4 The operating temperature range of the electronic components is $-40^{\circ}\text{C}\sim+80^{\circ}\text{C}$, and the temperature range of the LCD is $-20^{\circ}\text{C}\sim+80^{\circ}\text{C}$ (no LC display beyond the range, remote transmission is normal).

8.5 After commissioning, tighten the display and power cover to prevent water and moisture from entering the instrument.

9. Fault Analysis and Troubleshooting

fault Phenomenon	Cause of Failure	Solution
Deviation from the upper computer measurement	The parameter setting of the upper computer is incorrect, the line transmission is faulty.	Consistent setup of the supervisor and replacement of the transmission cable
False echoes are created before the real wave	Interference waves are caused by an obstacle in the measurement range	If the obstacle is fixed within the measurement range, the problem can be solved by changing the mounting position and false wave learning.
The transmitter shows negative numbers.	Internal "basic settings" of the instrument to adjust the low value setting, less than the actual height of	This can be done by setting the low adjustment value to the same height as the tank.

	the tank, the actual current output is 4 mA, that is zero point	
Instrument crashing during measurement	The instrument needs to be reset.	Reset the instrument, and set the relevant parameters, the additional parameters in the "material properties" item "heap angle" and "dust intensity" items to do the default processing. Set "No" can be.

10. Disassemble

10.1 Warning

Before disassembly, attention should be paid to hazardous process conditions, e.g., pressure inside the vessel, high temperature, corrosive or toxic medium.

10.2 Waste removal

Please follow the current regulations in each region for waste disposal.

11. Product Certification

Product Certification		
Certification	Certification No.	Certification Scope
SIL3	 NO.1N191227.DTEWT37	SIL 2 @ HFT=0; SIL 3 @ HFT=1, Route 2 _{ii}
EMC	 AE 50465135 0001	
Explosion-proof	 CCR1 17.2020X CCR1 18.1038X	Intrinsincally safe Ex ia IIC T1 ~ T5/T6 Ga Ex ia D 20 T85°C Flame-proof Ex d ia [ia Ga] II C T1~T5/T6 Gb Ex tD A21 T100°C / T85°C
Type Approve Certificate	 10F212-21	