

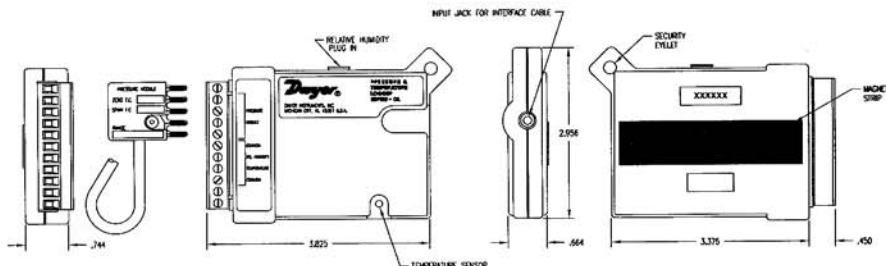

Series DL6 Pressure Datalogger

Specifications - Installation and Operating Instructions

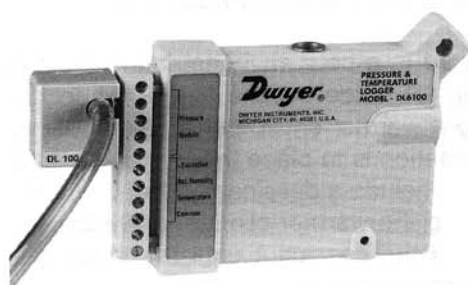

GENERAL

The Series DL6 Dataloggers are easy-to-use battery-powered data loggers that can monitor pressure, temperature, and relative humidity. The logger is designed to work with external sensors that can be ordered separately. The DL690 Temperature/Humidity sensor allows remote temperature and humidity sensing. The DL691 plug-in sensor records RH. Pocket -sized and rugged, they can be used in a wide range of environmental and industrial applications. Each unit can reliably record time-based data for later analysis, by TrendReader software and any IBM PC or 100% compatible computer.

Series DL dataloggers run continuously—constantly measuring and recording readings from any enabled channel. Self-powered by a long life lithium battery that will provide years of reliable operation, your logger can work independently from any external power supply or computer. Each Series DL6 Datalogger has an on-board thermistor that can be used to monitor and record ambient temperature.

GENERAL INSTALLATION (for all DL Loggers)

The TrendReader software must be installed on your computer prior to the use of any data logger described in this reference.

Setup

To setup your datalogger you must first have TrendReader software installed and running on your computer. You can then configure your logger with various options by plugging into your computer via the interface cable.

Set Sampling Rate

Always confirm the sampling rate (how often the logger takes readings) to make sure it will be acceptable to your application. You can alter the frequency at which the logger records readings by accessing Logger,

PHYSICAL DATA

No. of Channels: Five; internal thermistor, pressure module (included), plug-in humidity sensor, remote humidity/temperature sensor.
Internal Thermistor Range: -40 to 158°F (-40 to 70°C).
Internal Thermistor Resolution: 0.7°F (0.4°C), R25 value equal to 10,000Ω [10kΩ @ 25°C (77°F)].
Media: Air and noncorrosive gases.
Max. Pressure Rating: 4× rated pressure.
Compensated Temp Range: 32 to 158°F (0 to 70°C).
Accuracy: ±1% FS.
Thermal Accuracy: ±1% FS.
Stability: ±0.2% FS/yr.
Memory Size: 32,768 readings.
Resolution: 8 bits (1 in 256).

Sampling Methods:

Continuous (First-in, First-out) or Stop when full (Fill-then-stop).
Sampling Rates: Selectable from 8 seconds to once every 5 days.
Power: Built-in 3.6V Lithium battery, 1 Amp-hour.
Power Consumption: 5-10 μA, continuous.
Clock Accuracy: ±5 sec/day plus one sampling interval.
Ambient Operating Temp: -50 to 160°F (-45 to 70°C), 0 to 95% RH, non-condensing.
Connection: Removable screw terminal.
Computer Requirements: IBM compatible 386 or above and Windows™ 3.1 or later with 2mB RAM and 2mB hard drive disk space, one serial port.
Housing: Noryl™
Weight: 5 oz (110 g).

EQUATION

Description	Range	Equation #
Pressure Module	0 to 5 psig (30 kPa)	20
Pressure Module	0 to 30 psig (200 kPa)	8
Pressure Module	0 to 100 psig (700 kPa)	22
Internal Thermistor	-40 to 158°F (-40 to 70°C)	45

TABLE 1

Communicate, Setup, Sample rate in TrendReader software. Here you will be able to choose from a menu that gives the following interval alternatives: 8, 16, 32, 56 seconds, 2 minutes, 4 minutes and 56 seconds, 10 minutes, 20 minutes, and 30 minutes. The sampling rate will apply to all active channels on the logger.

Making External Connections

If you are using your logger to monitor external modules, sensors, or circuitry, make sure the connections are secure. Also, be sure the terminal block is snapped securely in the logger.

Enable Channels

Always make sure that you have enabled and verified the correct channels for your application. It can be very distressing to find out later that the information you hoped to collect was from an inactive channel. You can selectively enable additional channels in your logger as required. However, in order to avoid using logger memory unnecessarily, disable any channels which are not required.

Clear Memory

Before sending the logger out to the field to collect data, empty the logger memory. This will help to keep collected files smaller as well as decrease the time needed to backup the logger later. Note that clearing the logger's memory is automatic if you make setup changes (i.e. assign different equations, change filename, etc.)

Test

You can directly read the values that the logger is sensing, on a reading-by-reading basis, by using the real-time capability of the TrendReader software. To do this, choose Logger, Communicate, Realtime. Data on any enabled channel will be instantly displayed. Make sure the proper channels are enabled. This test gives an opportunity to check the logger setup and make necessary changes before the logger is placed in location for data collection.

Label

If working with more than one logger, label each, identifying the task and location before you distribute them throughout a building or system. To do this, simply use shipping tags. Later, when you retrieve them to graph their data, you will know what each graph refers to.

Mounting

Use the magnetic backing to conveniently mount the logger on metal surfaces like ductwork or electrical control cabinets. If concerned about theft, make sure to lock the logger to a permanent fixture using the special locking tab.

Special mounting methods (using Velcro® fasteners) to secure the loggers to other surfaces may be used. NOTE: Do not rely on the logger's magnetic strip for secure mounting if the surface is uneven, unstable, or above 150°F (65°C).

Cold or Humid Environments

The environment the logger will be placed in must be suitable, please refer to the physical data section. If conditions are not acceptable, consider using a protective enclosure. For humid environments, the logger can be protected by placing it in a ziplock plastic bag.

If the logger is used in a cold environment, make sure condensation will not settle on the logger when it is brought back into a warmer environment. The best way to prevent condensation is to place the logger in a plastic ziplock bag and include a desiccant. When you bring the logger back into the warmer climate, leave the logger in the bag with the desiccant until the logger has come to equilibrium with the environment.

Keep Track

Be sure to keep record of the locations of each logger. This will save time in looking for them when the data-gathering is completed. Also, keep track of when the loggers were put into service. This will help when producing graphs.

Retrieval

After sufficient time has passed to obtain a representative profile of data, retrieve the logger and bring it back immediately for analysis. Make sure the logger has a label so it can be properly identified and differentiated.

Analysis

To analyze the logger, you must first transfer a copy of its data into your computer. To do this, plug the logger into the TrendReader interface cable and choose Logger, Communicate, Backup. After describing the information to the computer, the data is automatically copied to disk, time and date stamped, and converted into the appropriate measurement units. A portion or the entire data set can be copied.

Each file will initially have the same descriptive title, but you can use Files, Revise Logger to alter these accordingly. To view graphs, choose Draw, New and select the appropriate file. A detailed description of all software functions can be found in the TrendReader Reference Guide.

INSTALLATION (specifically for DL6 Loggers)

The TrendReader software must be installed on your computer prior to the use of any data logger described in this reference.

Setup

To connect the pressure module, plug it into the five terminals as shown in figure 1. Make sure it is properly plugged in and secured to the terminal block.

Use TrendReader software to enable the pressure channel. Then assign the correct pressure equation for the model of pressure module you are using. If you want to switch from one pressure module to another you must change the equation number assigned to the pressure channel (Equation numbers are listed in table 1).

Pressure Measurement Precautions

The Series DL6 is designed for long-term trouble-free performance. Keep in mind a few precautions to maximize performance.

The pressure sensor is compatible with non-corrosive gases and moist air. IT IS NOT TO BE USED FOR LIQUID PRESSURE MEASUREMENT.

Always try to make your pressure connections separate from the module and logger. To accomplish this, leave a short length of tubing continually attached to the input port. Overstressing the input connection may cause it to break and thus cause erroneous readings.

DL690 Remote Temperature/Humidity Sensor

Use the DL690 for remote sensing. To connect the sensor, loosen the screws located on the logger's terminal block marked with Excitation, Relative Humidity, Temperature, and Common. Insert the corresponding wires on the sensor. Retighten the screws on the logger's terminal block (see figure 1).

DL691 Plug-In Humidity Sensor

Use the DL691 for local humidity sensing. To connect the sensor, simply plug the sensor into the top of the logger (see figure 1).

Remote Temperature Probe

Temperature can be monitored remotely using a NTC thermistor temperature probe (R25 value=10000Ω. Connect the probe to the corresponding screw terminals

WIRING CONNECTIONS

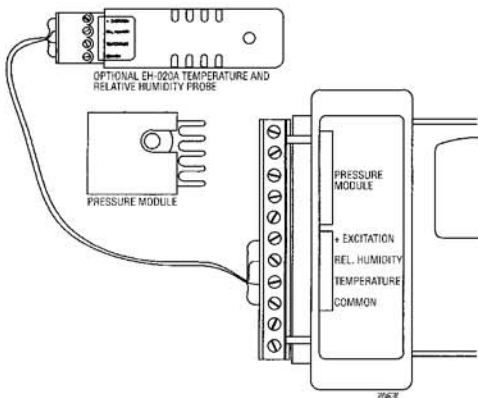

FIGURE 1

PRESSURE CALIBRATION

The pressure sensor, although subject to accuracy degradation when exposed to contaminants and/or extreme environmental conditions, will drift typically less than 1%/year (under clean conditions). Periodically check and if necessary, recalibrate or replace the pressure module. The recommended method of calibration is to use a pneumatic pressure calibrator with a preferred accuracy of 0.1% FS or better.

Procedure

1. Activate the pressure monitoring channel by accessing Logger, Communicate, Setup in the TrendReader software.
2. From the setup menu select View Realtime Reading function and, with the input port left unconnected (open to ambient), record the pressure reading (it should be close to zero if using a gauge sensor or close to ambient if using an absolute sensor).
3. Switch to Zero Calibration Adjustment function. Subtract the pressure reading recorded in step #2, from zero for a gauge sensor or from calibrator reading for the absolute sensor, and enter it for the low calibration adjustment.
4. Connect the logger's high input port to the calibrator, ensuring all connections are air tight.
5. Adjust the calibrator to produce a test pressure equal to the full scale range of the sensor. Switch back to the View Realtime Reading function and record the pressure reading.
6. Switch to Span Calibration Adjustment function. Subtract the pressure reading recorded in step #5, from the full scale range of the sensor (the calibrator reading should be the same), and enter it for the Mid Calibration Adjustment.
7. Save the calibration changes to the logger.

MAINTENANCE

No routine maintenance is required on the Series DL dataloggers. Periodic checks of connections and mounting is recommended. Please contact Dwyer Instruments, Inc. before returning unit for repair to review information relative to your application. When returning a product to the factory, carefully package and ship freight prepaid. Be sure to include a complete description of the application and problem and identify any hazardous material used with the product.

